

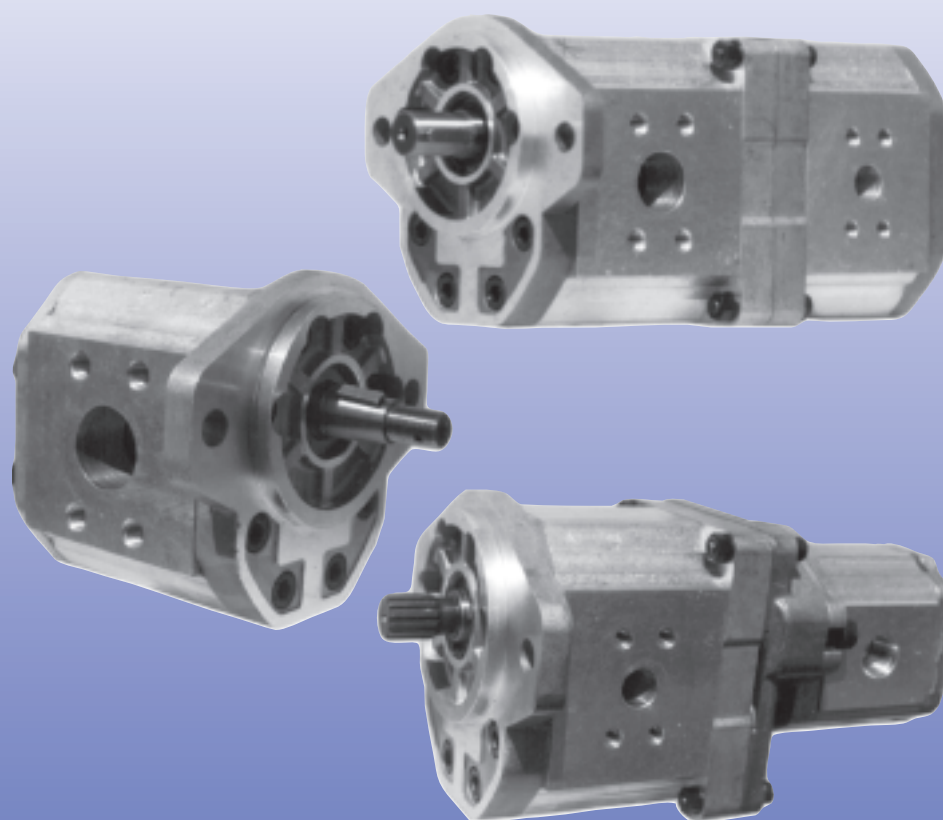













SNP3 • SEP3



Gear Pumps

Technical Information

Available Configurations, Pumps	Available Configurations, Motors
 <p>TFP 50 Pump DIN Flanges & Shaft 5 models 0.25-1.27 cm³ (0.015-0.074 in³) Speeds to 8000 rpm Pressures to 200 bar (2900 psi)</p>	 <p>TFM 100 Motors DIN Flanges & Shafts 6 models 2.60-7.8 cm³ (0.158-0.464 in³) Speeds to 3000 rpm Pressures to 200 bar (2900 psi)</p>
 <p>TFP 100 Pumps SAE "AA" & DIN Flanges & Shafts 7 models 1.20-7.8 cm³ (0.071-0.464 in³) Speeds to 5000 rpm Pressures to 210 bar (3000 psi)</p>	 <p>SNM2 Motors SAE "A" & DIN Flanges & Shafts 10 models 6-25.2 cm³ (0.366-1.54 in³) Speeds to 4000 rpm Pressures to 250 bar (3600 psi) NOTE: SNU2 Uni-directional motor available in 8.4-25.2 cm³ (0.513-1.54 in³)</p>
 <p>SNP2 Pumps SAE "A" & DIN Flanges & Shafts 11 models 3.4-25.2 cm³ (0.24-1.54 in³) Speeds to 4000 rpm Pressures to 250 bar (3600 psi)</p>	 <p>TAM2290 Motors SAE "B" & DIN Flanges & Shafts 9 models 22-90 cm³ (1.34-5.49 in³) Speeds to 3000 rpm Pressures to 210 bar (3000 psi) NOTE: TAU2290 Uni-directional motor available in the same displacements</p>
 <p>SP2.5/250 Pumps SAE "A" & "B" 2-Bolt Flanges SAE "A" & "B" 11T & 13T spline shafts SAE "A" & "B" .75" & .875" keyed shafts 8 models 20-45 cm³ (1.22-2.75 in³) Speeds to 3000 rpm Pressures to 250 bar (3600 psi) Priority Flow Divider Covers</p>	<p style="text-align: center;">Fan Drive Systems</p>  <p>Available in 5 to 36 HP configurations Fan speed modulated based temperature Options for additional inputs Contact Sauer-Sundstrand for details and specifications</p>
 <p>SNP3 Pumps SAE "B" & DIN Flanges & Shafts 10 models 22.1-88.2 cm³ (1.35-5.38 in³) Speeds to 3000 rpm Pressures to 250 bar (3600 psi) NOTE: The SEP3 is available in the 22.1-44.1cm³ (1.35-2.69 in³) displacements for applications not requiring the pressure capabilities of the SNP3 or CP180.</p>	<p style="text-align: center;">Steering Pumps</p>  <p>Available in 8-45 cm³ (0.49-2.75 in³) Special and or engine mount available (ie Perkins, Deutz, Kubota, etc.) Flanges and shafts for several engines Contact Sauer-Sundstrand for details and specifications</p>
 <p>CP180 Pumps SAE "B" Flanges & Shafts 11 models 31.79-95.7 cm³ (1.94-5.38 in³) Speeds to 3200 rpm Pressures to 250 bar (3600 psi) Priority Flow Divider Covers</p>	
 <p>CP222 Pumps SAE "C" 2 & 4-Bolt Flanges & Shafts 7 models 64.8-162.0 cm³ (3.95-9.89 in³) Speeds to 3000 rpm Pressures to 250 bar (3600 psi)</p>	

****NOTE:** All pumps can be incorporated into multiple pump configurations. Contact Sauer-Sundstrand for details and specifications.

Sauer-Sundstrand Gear Pump and Motor Features

- Worldwide sales and service capabilities from the industry leader is part of the package for every Sauer-Sundstrand gear product customer.
- Proven reliability with over 45 years of experience in gear product design for mobile and industrial applications.
- System pressures to 4000 psi (276 bar) and speeds to 8,000 rpm allow high performance in system design.
- Pressure balanced design for high efficiency and long life.
- Low cost design and manufacturing for the requirements of fixed displacement systems.
- Variety of flexible installation options available:
 - SAE, Metric, and European flanges, shafts and ports
 - Convenient side or rear porting options
 - Auxiliary through drive SAE mounting pads
 - Integral relief valve, priority flow control, and priority flow divider covers
 - High temperature viton seals optional
 - Multiple pump configurations (refer to the Quick Reference chart below)

Quick Reference - Multiple Pump Configurations

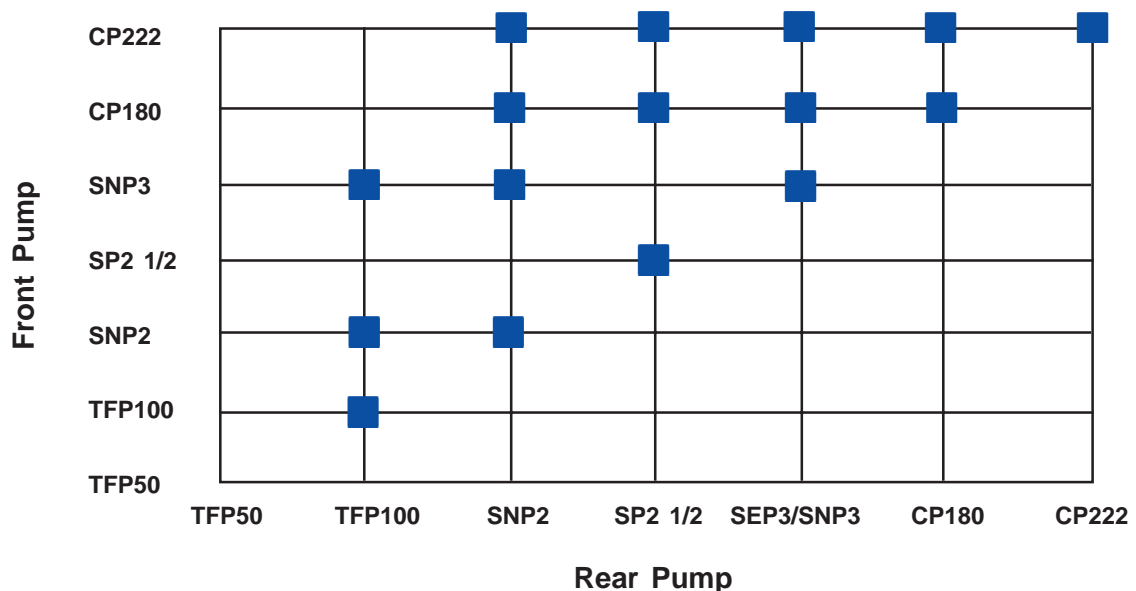

Contents

Sauer-Sundstrand Gear Pump and Motor Features 3
A Complete Family of Sauer-Sundstrand Gear Pumps and Motors 5
SNP3 5
SEP3 5
Technical Features 6
DESIGN 6
Pump Sizing Calculations 10
SNP3 Technical Data 11
SNP3 Performance Curves 12
Dimensions for SNP3 Configurations CO 01 • CI 01 • SC 01 17
Dimensions for SNP3 Configurations CI 02 • CO 02 • SC 02 18
Dimensions for SNP3 Configurations CI 03 • CO 03 • SC 03 19
Dimensions for SNP3 Configurations CI 06 • CO 06 • SC 06 20
Dimensions for SNP3 Configurations CI 07 • SC 07 / 1)CI 07E • 1)SC 07E 21
Type Designation and Order Code, SNP3 22
SEP3 Technical Data 23
SEP3 Performance Curves 24
Dimensions for SEP3 Configurations CI 01 • SC 01 27
Dimensions for SEP3 Configurations CI 07 • SC 07 28
Type Designation and Order Code, SEP3 29
SNP3 Tandems 30
Dimensions for Tandem Gear Pump Configuration • PRR ... + CO 41 (SNP 3 + SNP 3) 31
Dimensions for Tandem Gear Pump Configuration • PRR ... + SC 47 (SNP 3 + SNP 3) 32
Dimensions for Tandem Gear Pump Configuration • PRR ... + SC 37...2 (SNP 3 + SNP 3) 33
Dimensions for Tandem Gear Pump Configuration • PRN ... + CO 31 (SNP 3 + SNP 3) 34
Dimensions for Tandem Gear Pump Configuration • PRN ... + SC 37 (SNP 3 + SNP 2) 35
Dimensions for Tandem Gear Pump Configuration • PRN ... + SC 37...2 (SNP 3 + SNP 2) 36
Type Designation and Order Code, SNP3 Tandems 37
Flow vs Speed 38

A Complete Family of Sauer-Sundstrand Gear Pumps and Motors

Quick Reference - Displacement/Model

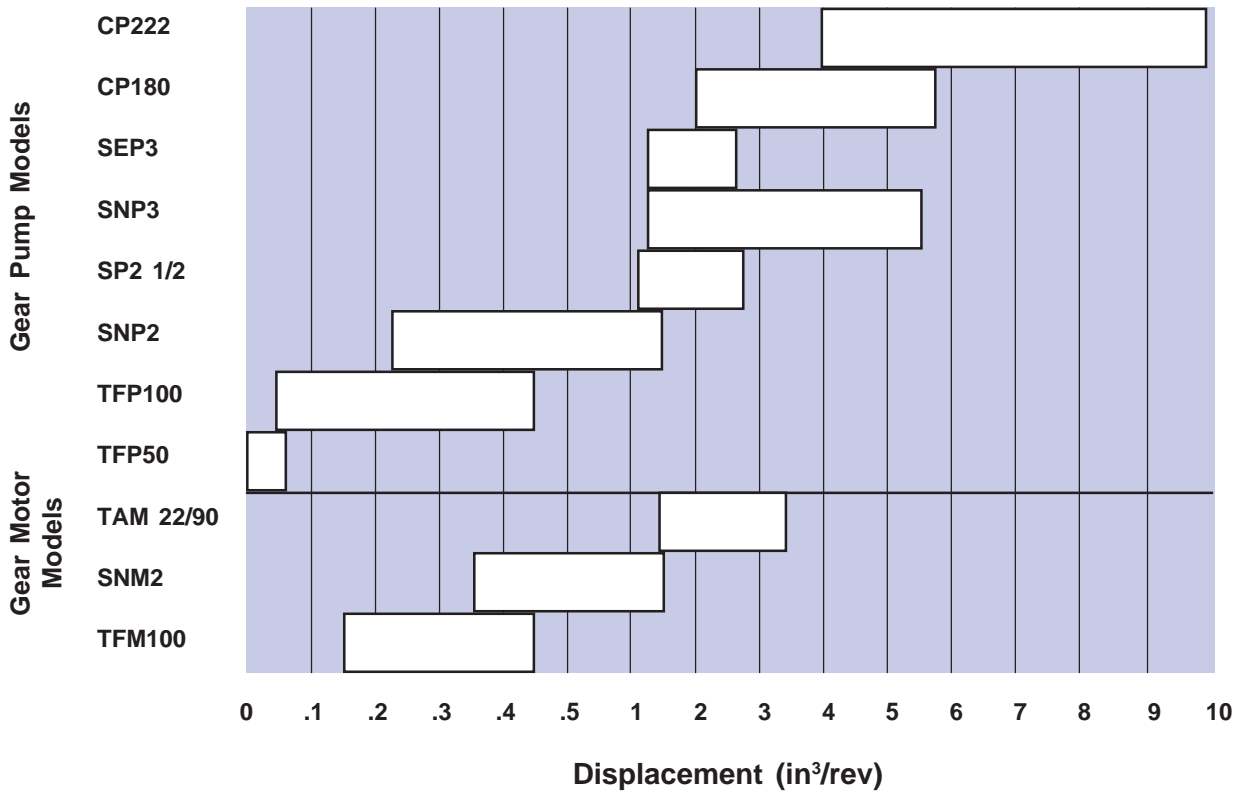

SNP3

The SNP3 series pump replaces the TAP2290 Series pump. The SNP3 offers an additional model in the range as well as higher volumetric and torque efficiencies due to improved machining techniques and a new pressure balance design. Peak pressure capabilities have been increased to 3910 PSI. The overall length of the SNP3 is 4.5 mm (.177 inch) longer than existing TAP2290 units and can be used in single or multiple pump combinations. Adapter kits used for multiple pump combinations are the same as those used with the TAP2290. There are no components required when changing rotation. The SNP3 range is available in 22.1 cm³ (1.35 in³) to 88.2 cm³ (5.38 in³) displacements.

SEP3

The SEP3 series pump is a cost effective alternative for applications not requiring the high pressure capabilities of the SNP3 or CP180 series. The SEP3 design utilizes a bearing block design without the floating pressure plates as on the SNP3. Overall efficiencies are similar to SNP3. However, pressure capabilities are reduced. The SEP3 range is available in 22.1 cm³ (1.35 in³) to 44 cm³ (2.69 in³) displacements.

Technical Features

DESIGN

Sauer Sundstrand gear pumps and motors utilize an external spur gear, positive displacement design of proven low pressure high efficiency. These high performance pumps are constructed of a three piece aluminum body which has been proven in over 30 years experience in hydraulic products for mobile and industrial applications. The extruded aluminum housing provides the necessary strength construction while providing a very high power to weight ratio and increased heat dissipation. Most importantly, the aluminum center section permits the gear teeth to inlet create their own path for maximum radial gear tip seal and high volumetric efficiency.

Figure 1:

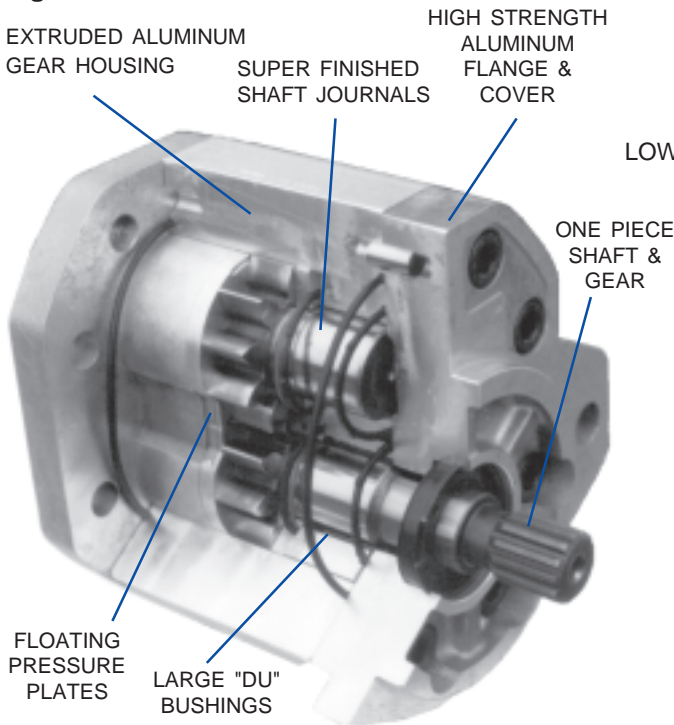

PRECISE GEAR ALIGNMENT

Cast aluminum bearing blocks are fitted to the gear pockets for precise alignment. Since all parts are contained in the housing the possibility of misalignment is eliminated. The load is carried uniformly without stress being applied to either the end cap or the front cover. Teflon coated pressure lubricated bronze bushings in each bearing block ensure a long operating life.

ROBUST CONSTRUCTION

One piece gear/shaft construction provides both high strength and an accurate profile. Each integral gear/shaft is constructed of bearing quality hardened steel which is machined to precise tolerance for minimum leakage. The one piece design also eliminates the potential problems of stress fatigue often associated with two piece designs.

Figure 2:

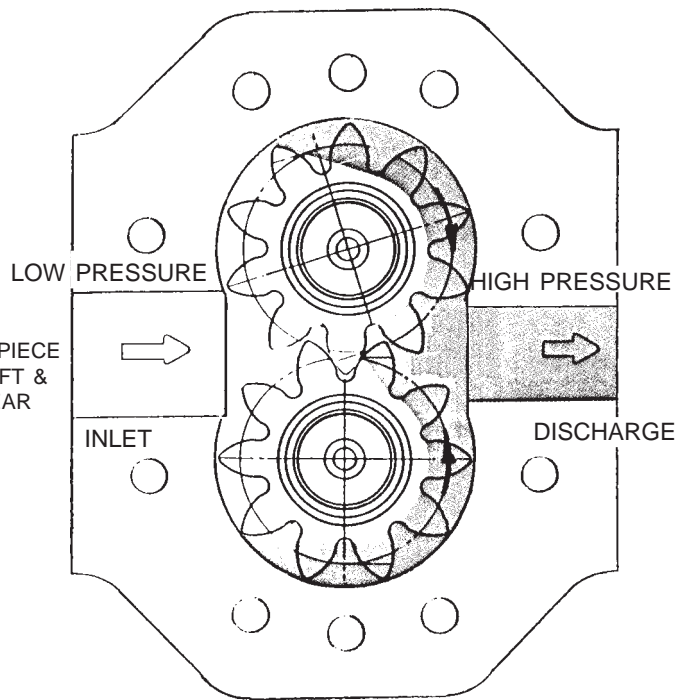

LEAK PROTECTION

Standard are Buna seals to prevent leakage and migration of fluids from the hydraulic circuit to the gear box or atmosphere. Viton Shaft seals are available.

Technical Features, Continued

PRESSURE BALANCE

Pressure balance plates on each side of the gears contribute to high volumetric efficiency and maximum seal on all SauerSundstrand pump and motor models.

The TFP100 and SNP2 models are each equipped with thick pressure plates which function as part of the bearing block. The SNP3 has thin pressure plates which provide high efficiency at both low and high speed for maximum efficiency throughout the speed range. See Figure 3.

Accurately defined pressure zones at the rear faces of the bearing blocks receive oil under pressure which loads the bearing against the gear side face. Contact force between bearing face and gear is low and precisely controlled across wide speed, pressure and temperature ranges. The result is typical volumetric efficiencies in the range of 95% through effective sealing between gear and bearing faces—without causing undue wear or overheating between these faces.

In order to prevent pressure trapping in between

the meshing gear teeth, channels in the bearing blocks permit relief of the trapped fluid to the suction side of the pump.

The thin pressure balance plates also separate the pressure balance from the bearing load, thus permitting the pressure plates to function independently of bearing load. This permits the balance plates to accept higher radial loading and some loading in either direction. Running clearances are maintained tight enough to minimize leakage across the gear faces, yet sufficient to maintain the oil film between mating surfaces for minimum wear. As pressure increases, the sealing efficiency increases proportionally.

Teflon impregnated D.U. bushings on all pumps and motor models provide infinite life within the design load range. Unlike antifriction bearings, D.U. bushings do not present a B10 life problem. Teflon and pressure lubrication contribute to an indefinite operating life as long as the system is properly maintained. See Figure 4.

The large bearing size provides adequate support under all normal operating conditions. Since the

Figure 3:

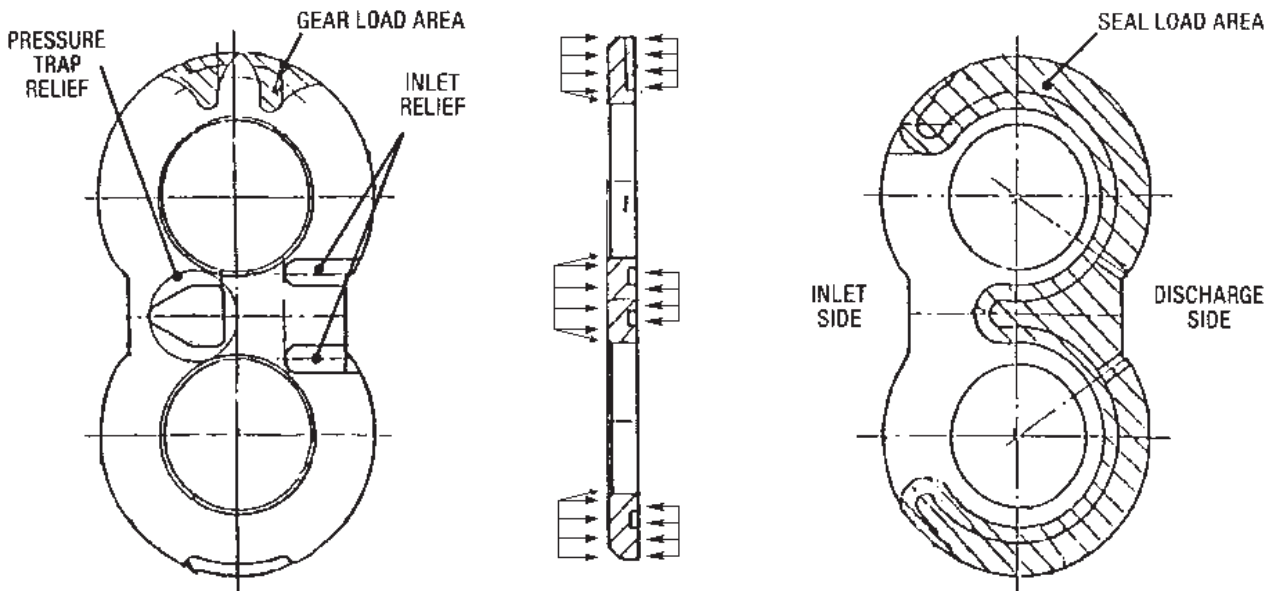

Technical Features, Continued

bushing blocks and gears are contained in the same housing section, self alignment is ensured. As a result, Sauer-Sundstrand gear pumps are capable of higher pressure and efficiency than many pumps of equal displacement

DRIVE CONDITIONS

Most Sauer-Sundstrand gear products are available SAE standard spline or straight keyed drive shafts for direct or indirect drive applications. A three piece coupling is the preferred method of direct drives, thereby eliminating radial and axial loading.

Rigid splines may be used providing the mounting pilot should be aligned within .002 in. (.05 mm) on center [.004 (.10 mm) TIR].

Both concentricity and angular alignment of shafts are important to pump life. Misalignment can induce heavy side loads on bearing and seals, causing premature failure.

Overhung load drives (chain, belt, or gear) are permissible. Contact Sauer-Sundstrand for assistance.

Figure 4:
The DU® Bearing

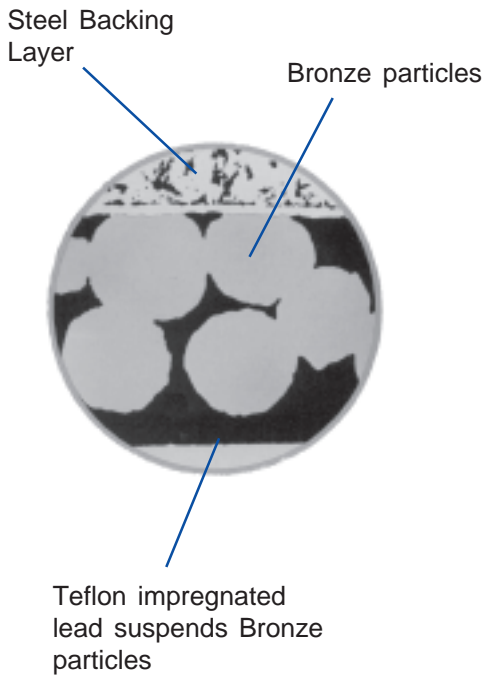

DU® is a trademark of the Garlock Bearing Company

FILTRATION

A wire gauze strainer with a mesh opening of 90 micron (170 mesh) should be incorporated into the pump inlet line from the reservoir. The size of the suction strainer is determined by the limiting suction condition and must be correctly sized and cleaned on a regular basis to prevent cavitation.

A full flow 10 micron filter should be used in the system return line to trap all contaminants before they enter the reservoir.

Since the filter must be changed at regular intervals, the filter housing should be located in an accessible area.

OPERATING TEMPERATURES

With Buna seals and normal operating conditions, the system temperature should not exceed 180° F (82°C) except for short periods to 200° F (93° C).

With optional Viton elastomers, the system may be operated at continuous temperatures up to 225° F (107° C) without damage to the pump.

CAUTION: Operation in excess of 225° F may cause external leakage or premature unit failure.

FLUIDS

A mineral based fluid is recommended with additives to resist corrosion, oxidation and foaming. The oil should have the maximum viscosity commensurate with system pressure drop and pump suction levels. The viscosity at any running condition must be between 45 SSU minimum and 250 SSU maximum continuous.

Since the fluid used serves as a system lubricant, as well as transmitting power, careful selection of the fluid is important for proper operation of the unit and satisfactory life of the pump and components.

SUCTION

For maximum pump life, the inlet vacuum should not exceed 4 inches (100 mm) Hg . at the pump inlet. For cold start conditions, vacuum up to 12 inches (300 mm) Hg. is acceptable for short durations.

Both cavitation and the possibility of aeration increase with higher inlet vacuum. In addition, oil film lubrication is disrupted by high inlet vacuum. Both factors, either singularly or combined, may contribute to a decrease in pump life.

CAUTION: Continuous operation at vacuums in excess of 4 inches Hg. may cause premature unit failure.

Technical Features, Continued

MAXIMUM SPEED

Maximum speed is limited by gear tooth filling and surface speeds centrifugal gear teeth filling. Unless otherwise specified, maximum rated pump speeds listed in this manual are based on operation at sea level with SAE oil having a viscosity of 120 SSU at 122° (50° C). Speed limits for a particular application depend on inlet pressure and oil viscosity. Consult Sauer-Sundstrand for operation outside these limits.

MINIMUM SPEED

Minimum recommended operating speed, at rated pressure, varies from 480 RPM to 1100 RPM depending upon pump size. Minimum speed is limited by volumetric efficiency. If lower than recommended starting or operating speeds are required, contact Sauer-Sundstrand for assistance.

For motors, minimum speeds listed are for continuous operation at rated pressure. Motors may be started from zero speed on drives where torque typically increases with speed. Repeated starts under high load conditions are not recommended. No load start up pressures range from 300 to 600 PSI (20.7 to 41.4 BAR).

INPUT TORQUE RATINGS

The individual product dimensional configurations in this catalog list the maximum continuous input torques for various shaft options.

When applying pumps in tandem or multiple, observe that input torque limitations must be met for each section and cumulative sections.

Always insure that the rear pump on a tandem unit does not exceed its torque rating.

CAUTION: Torques in excess of those shown may cause premature input shaft or unit failure.

MOUNTING

The pump mount / drive should be designed to minimize axial and radial loads on the shaft. When using indirect (chain, belt, or gear) drive, contact Sauer-Sundstrand to determine permissible load limits and direction of installation.

PIPING

The choice of piping size and installation should always be consistent with maintaining minimum ve

locity. This will reduce system noise, pressure drops and overheating, thereby adding to cost savings for both the construction and operation of the system.

Inlet piping should be designed to prevent continuous pump inlet vacuums in excess of 4 in. (100 mm) Hg. or 12 in. (300 mm) Hg. during start-up when measured at the inlet port.

RESERVOIR

The reservoir should be designed to accommodate maximum volume changes during all system operating modes and prevent aeration of the fluid as it passes through the tank. Return and inlet lines should be positioned below the reservoir low oil level and be located as far as possible from each other. A baffle plate located between the pump inlet and return line is desirable to allow the oil to deaerate before it enters the pump.

Reservoirs are normally sized for at least one-half the maximum pump flow for adequate oil deaeration.

COOLING

Depending on duty cycle and reservoir/line construction, an oil cooler may be required. This is sized based on typical power losses in the hydraulic circuit. The oil cooler is usually placed in the return line.

CAVITATION

Hydraulic oil used in the majority of systems contains about 10% dissolved air by volume. This air under certain conditions of vacuum within the system is released from the oil causing air bubbles. These air bubbles collapse if subjected to pressure, and this collapse creates erosion of the adjacent metal. Because of this, it becomes obvious that the greater the air content within the oil, or the greater the vacuum in the inlet line, the more severe will be the resultant erosion.

The main causes of over-aeration of the oil are air leaks, particularly on the inlet side of the pump, and flow line restrictions such as inadequate pipe sizes, elbow fittings and sudden changes in flow line cross sectional area. Providing these defects are avoided; pump inlet pressure and rated speed requirements are maintained; and reservoir size and location is adequate, no cavitation problems should occur with Sauer-Sundstrand pumps and motors.

Technical Features, Continued

PRESSURE RATINGS

Sauer-Sundstrand pumps are designed to operate continuously at rated pressure. The maximum relief valve setting must be set above rated pressure and below peak pressure (relief valve overshoot). Lower operating pressure will extend the life of the unit.

PRESSURE PROTECTION

The pump, as well as other system components, has pressure limitations. Thus a relief valve must be installed in the system, preferably as close to the pump as possible, to protect it from excessive pressure. If the relief valve is set at or near the maximum pressure rating for the pump, the operating characteristics of the valve should be known so that common relief valve overshoot does not allow system pressure to exceed the pump rating.

CAUTION: Failure to install this relief valve may result in premature unit failure.

PRESSURE RATINGS

Sauer-Sundstrand pumps are designed to operate continuously at rated pressure. The maximum relief valve setting must be set above rated pressure and below peak pressure (relief valve overshoot). Lower operating pressure will extend the life of the unit.

LIFE EXPECTANCY

All Sauer-Sundstrand gear pumps utilize pressure balanced journal bearings which have an oil film maintained between the gear / shaft and bearing surfaces at all times. If this oil film is sufficiently sustained through proper system maintenance and operating limits are adhered to, a high life can be expected.

NOTE: A B-10 type life expectancy number is generally associated with anti-friction bearings and does not exist for journal bearings.

Pump Sizing Calculations

Si System

$$\text{Output flow } Q_e = \frac{Vg \cdot n \cdot \eta_v}{1000} \quad \text{l/min}$$

$$\text{Input torque } M_e = \frac{Vg \cdot \Delta p}{20 \cdot \pi \cdot \eta_{mh}} \quad \text{Nm}$$

$$\text{Input Power } P = \frac{M_e \cdot n}{9550} = \frac{Q_e \cdot \Delta p}{600 \cdot \eta_t} \quad \text{kW}$$

Vg = Displacement per revolution in cm^3

p_{HD} = High pressure, in bar

p_{ND} = Low pressure, in bar

Δp = $p_{HD} - p_{ND}$ bar (System pressure)

n = Speed rpm (min^{-1})

η_v = Volumetric efficiency, (%)

η_{mh} = Mechanic - hydraulic efficiency, (%)

η_t = Overall efficiency, (%)

English System

$$\text{Output flow } Q_e = \frac{Vg \cdot n \cdot \eta_v}{231} \quad \text{gal/min}$$

$$\text{Input torque } M_e = \frac{Vg \cdot \Delta p}{2 \cdot \pi \cdot \eta_{mh}} \quad \text{in} \cdot \text{lb}$$

$$\text{Input Power } P = \frac{M_e \cdot n}{9550} = \frac{Q_e \cdot \Delta p}{1714 \cdot \eta_t} \quad \text{HP}$$

Vg = Displacement per revolution in in^3

p_{HD} = High pressure, in psi

p_{ND} = Low pressure, in psi

Δp = $p_{HD} - p_{ND}$ psi (System pressure)

n = Speed rpm (min^{-1})

η_v = Volumetric efficiency, (%)

η_{mh} = Mechanic - hydraulic efficiency, (%)

η_t = Overall efficiency, (%)

SNP3 Technical Data

Table 1: SNP 3

SNP 3	Dimension	Frame Size									
		22	26	33	38	44	48	55	63	75	90
Displacement	cm ³	22.1	26.2	33.1	37.9	44.1	48.3	55.1	63.4	74.4	88.2
	in ³ /Rev	1.35	1.60	2.02	2.32	2.69	2.93	3.36	3.87	4.54	5.38
¹ Maximum Speed	rpm	3000	3000	3000	3000	3000	3000	2500	2500	2500	2500
	bar	250	250	250	200	200	200	180	180	100	100
	psi	3625	3625	3625	2900	2900	2900	2610	2610	1450	1450
¹ Maximum Pressure	bar	250	250	250	250	250	230	230	210	180	150
	psi	3600	3625	3625	3625	3625	3335	3335	3045	2610	2175
	rpm	3000	3000	3000	2800	2800	2800	2300	2300	2300	2300
² Maximum Peak Pressure	bar	270	270	270	270	270	250	250	230	200	170
	psi	3910	3910	3910	3910	3910	3625	3625	3335	2910	2465
Minimum Speed at Maximum Pressure	rpm	800	800	800	800	800	800	800	600	600	600

¹Maximum pressure not to exceed for 210 bar (3000 psi) for frame sizes 22-55 using threaded ports such as O-ring boss, BSP, or metric threads.

²Maximum pressure not to exceed for 230 bar (3300 psi) for frame sizes 22-55 using threaded ports such as O-ring boss, BSP, or metric threads. Relief Valve must be set between Maximum Peak Pressure and Maximum Pressure.

Figure 5:

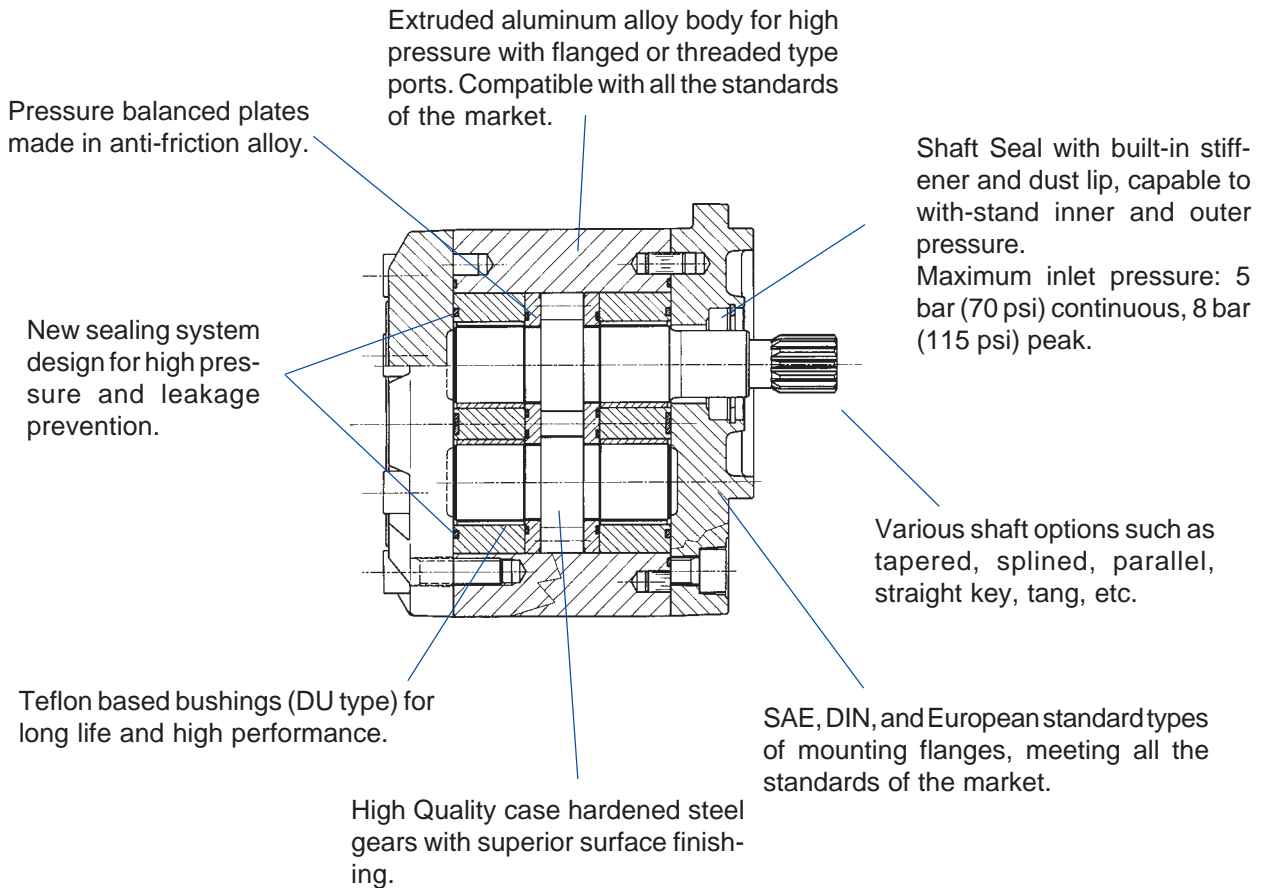

SNP3 Performance Curves

[$\nu = 25 \text{ mm}^2/\text{s}$ (120 SUS), $\vartheta = 50^\circ \text{ C}$ (122°F)]

Figure 6:

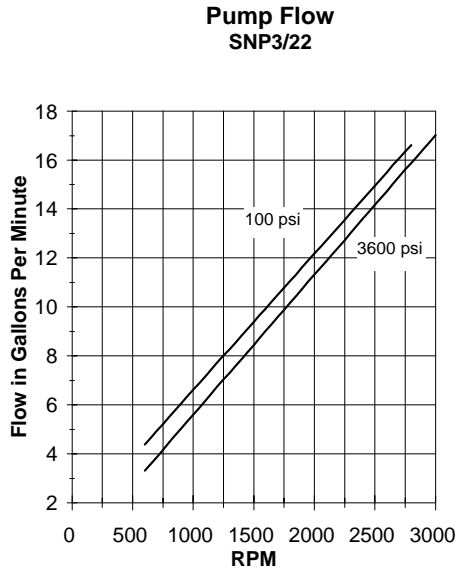

Figure 7:

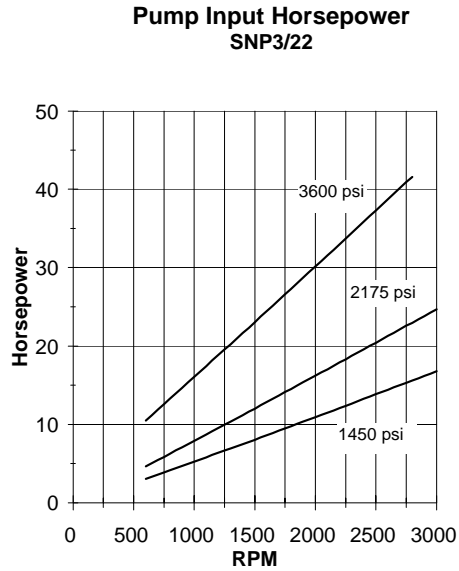

Figure 8:

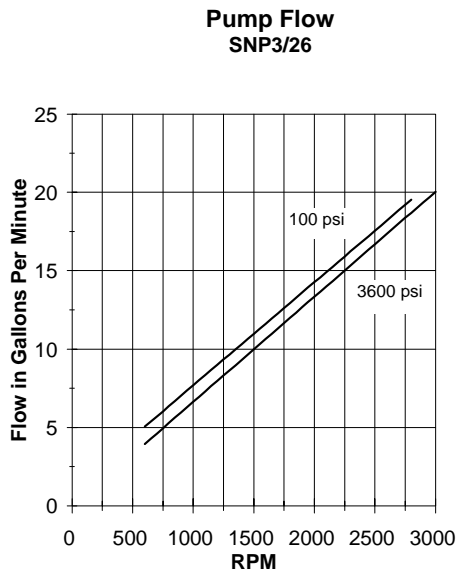
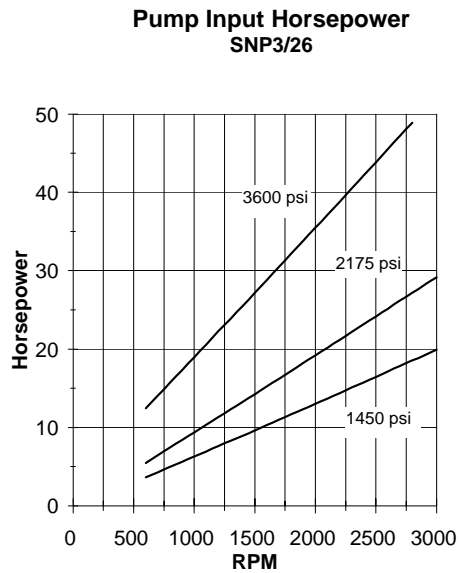

Figure 9:



SNP3 Performance Curves, (Continued)

[$\nu = 25 \text{ mm}^2/\text{s}$ (120 SUS), $\vartheta = 50^\circ \text{ C}$ (122°F)]

Figure 10:

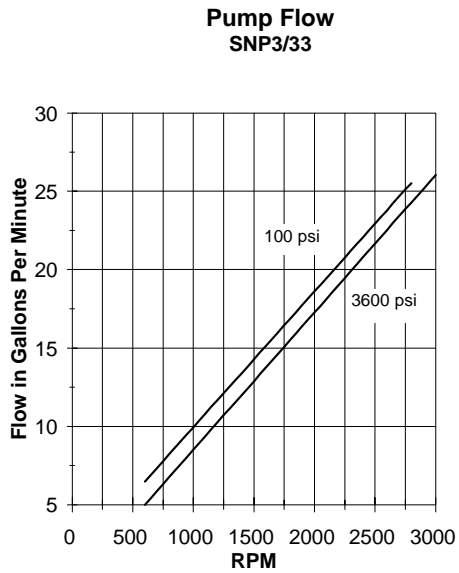

Figure 11:

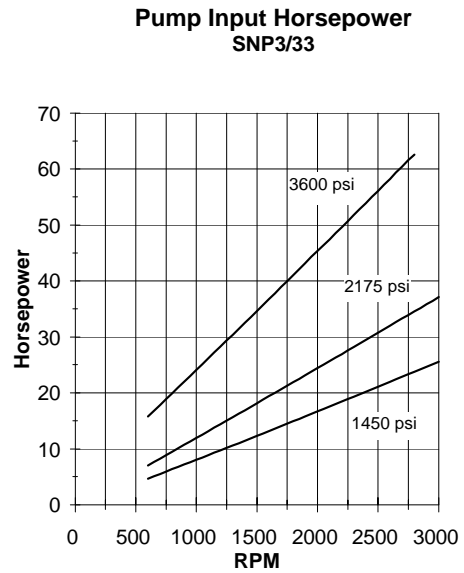

Figure 12:

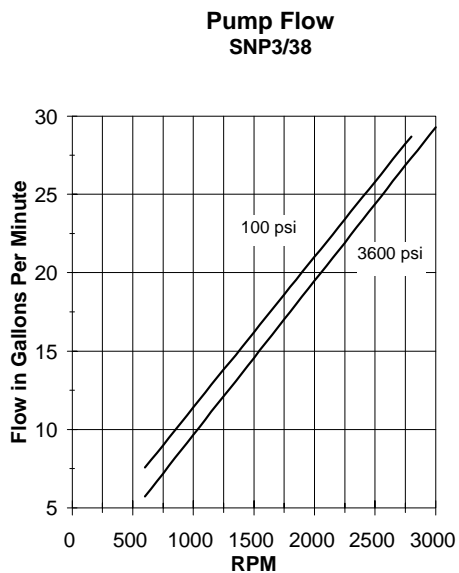
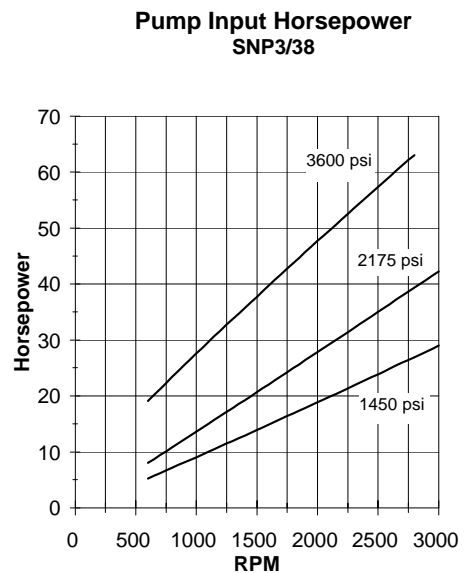

Figure 13:



SNP3 Performance Curves, (Continued)

[$\nu = 25 \text{ mm}^2/\text{s}$ (120 SUS), $\vartheta = 50^\circ \text{ C}$ (122°F)]

Figure 14:

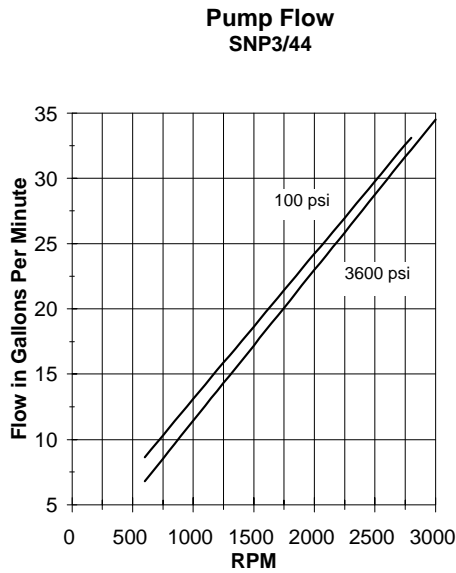

Figure 15:

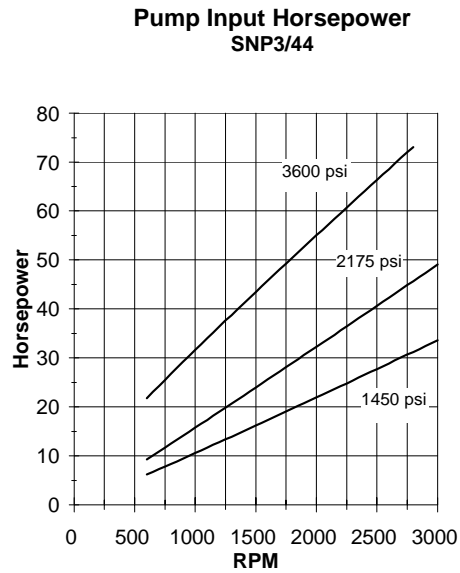

Figure 16:

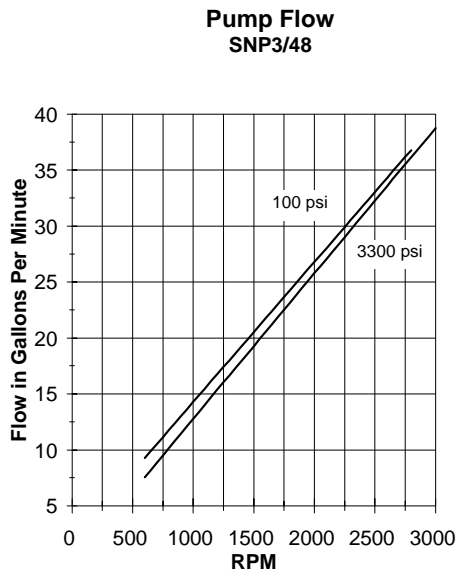
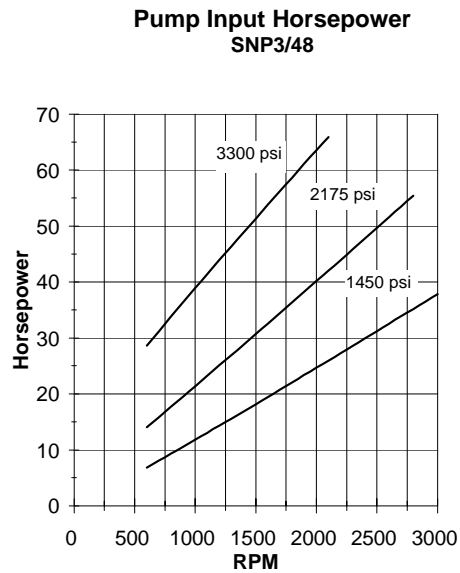

Figure 17:



SNP3 Performance Curves, (Continued)

[$\nu = 25 \text{ mm}^2/\text{s}$ (120 SUS), $\vartheta = 50^\circ \text{ C}$ (122°F)]

Figure 18:

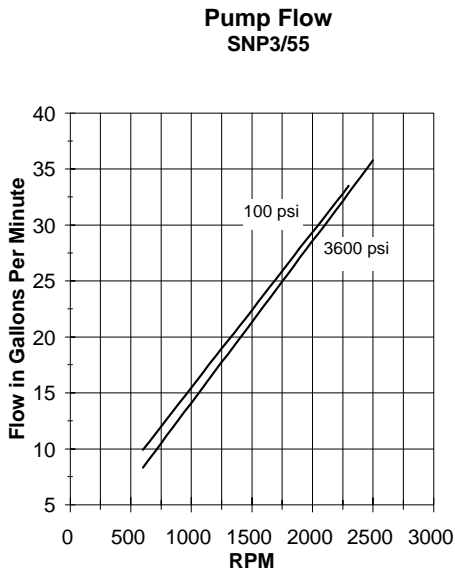

Figure 19:

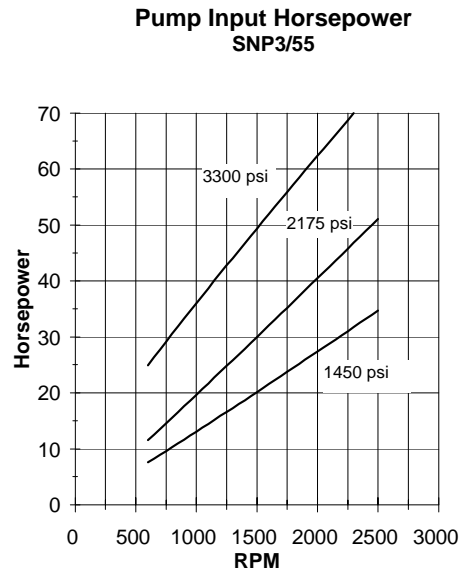

Figure 20:

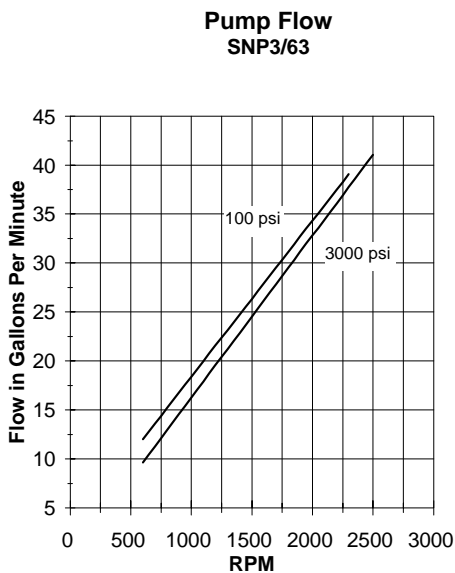
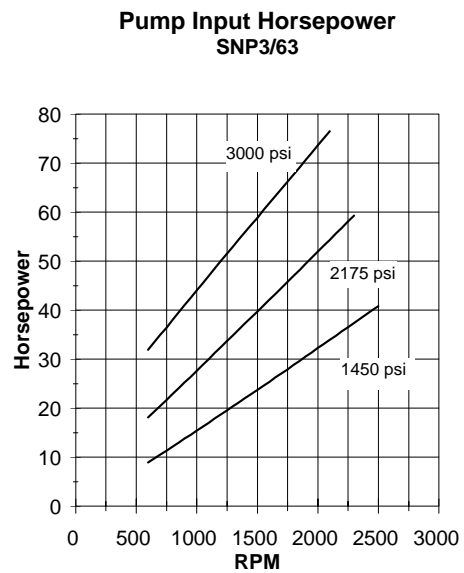

Figure 21:



SNP3 Performance Curves, (Continued)

[$\nu = 25 \text{ mm}^2/\text{s}$ (120 SUS), $\vartheta = 50^\circ \text{ C}$ (122°F)]

Figure 22:

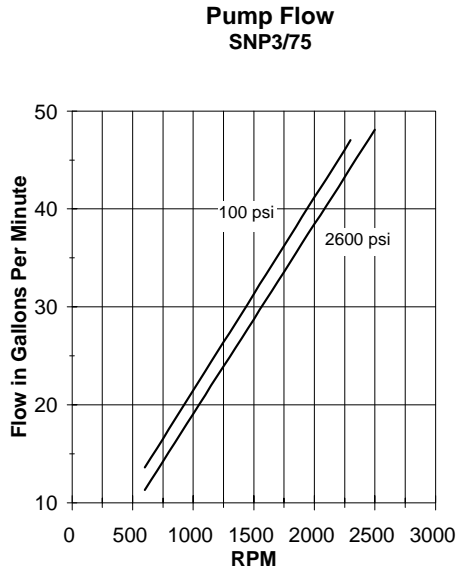

Figure 23:

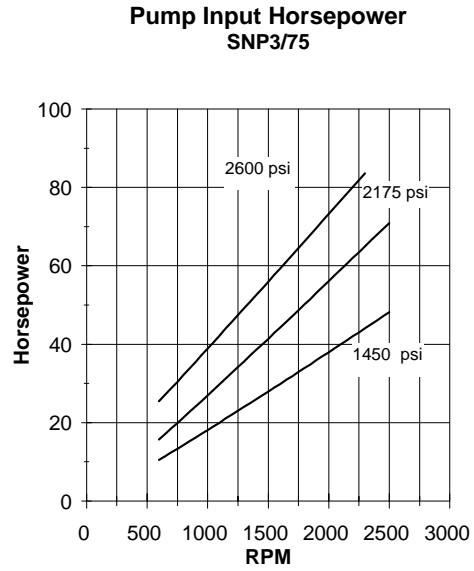

Figure 24:

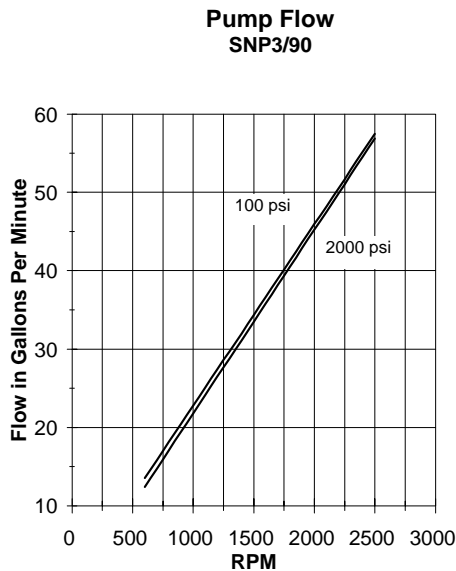
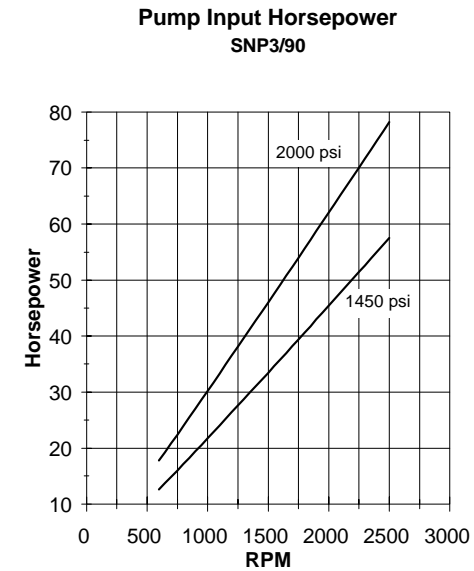

Figure 25:



Dimensions for SNP3 Configurations CO 01 • CI 01 • SC 01

Figure 26:

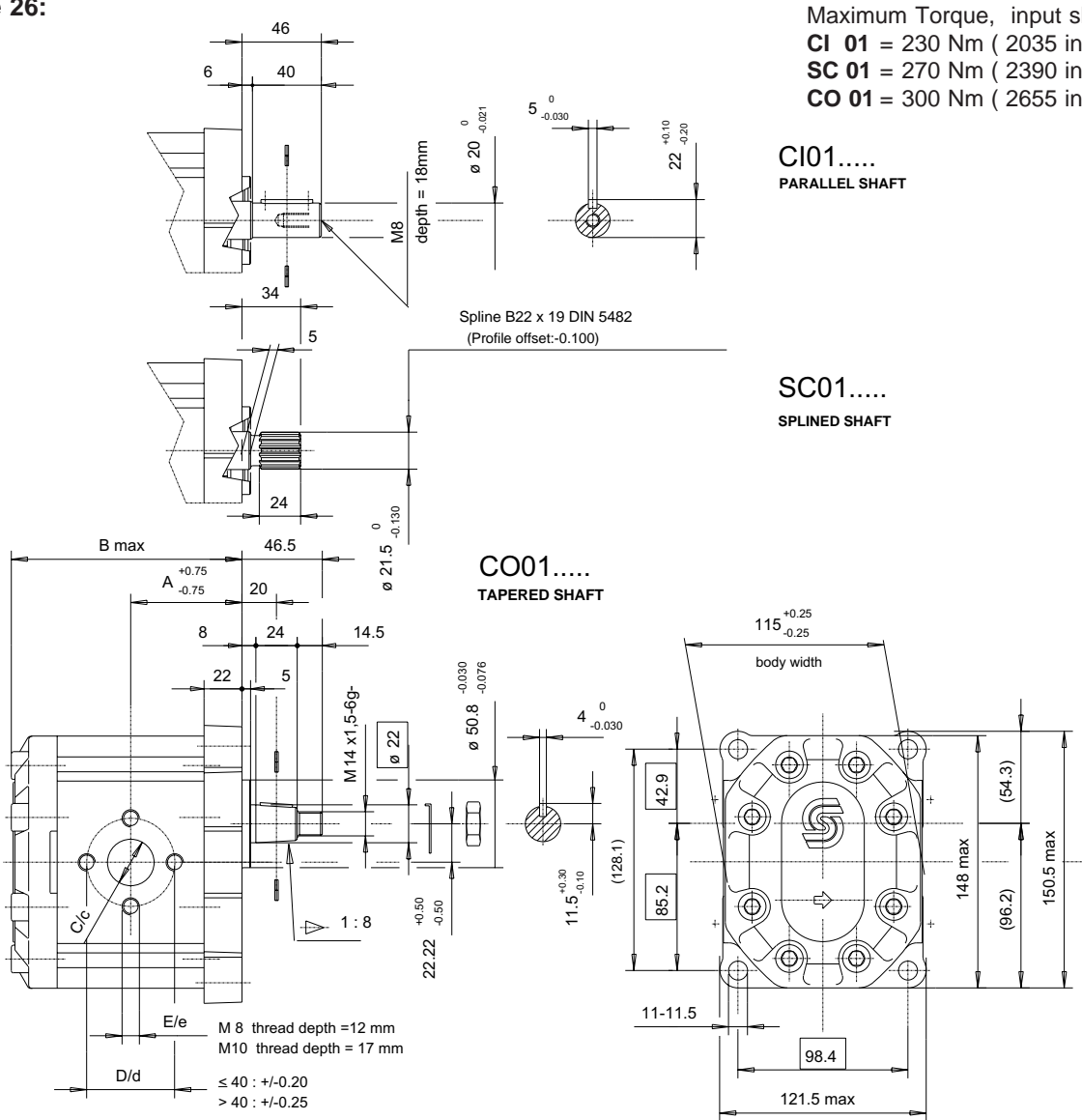

Table 2: Dimensions

SNP 3 Frame Size		22	26	33	38	44	48	55	63	75	90		
Dimensions	A	mm	63.00	64.50	67.00	68.80	71.00	72.50	75.00	78.00	82.00	87.00	
		in	2.48	2.54	2.64	2.71	2.80	2.85	2.95	3.07	3.23	3.43	
	B	mm	132.50	135.50	140.50	144.00	148.50	151.50	156.50	162.50	170.50	180.50	
		in	5.22	5.33	5.53	5.67	5.85	5.96	6.16	6.40	6.71	7.11	
	European Inlet Port	C	20 mm (0.79 in)			27 mm (1.06 in)			36 mm (1.42 in)				
		D	40 mm (1.57 in)			51 mm (2.01 in)			62 mm (2.44 in)				
		E	M8			M10			M10				
	European Outlet Port	c	20 mm (0.79 in)				27 mm (1.06 in)						
		d	40 mm (1.57 in)				51 mm (2.01 in)						
		e	M8				M10						

Dimensions for SNP3 Configurations CI 02 • CO 02 • SC 02

Figure 27:

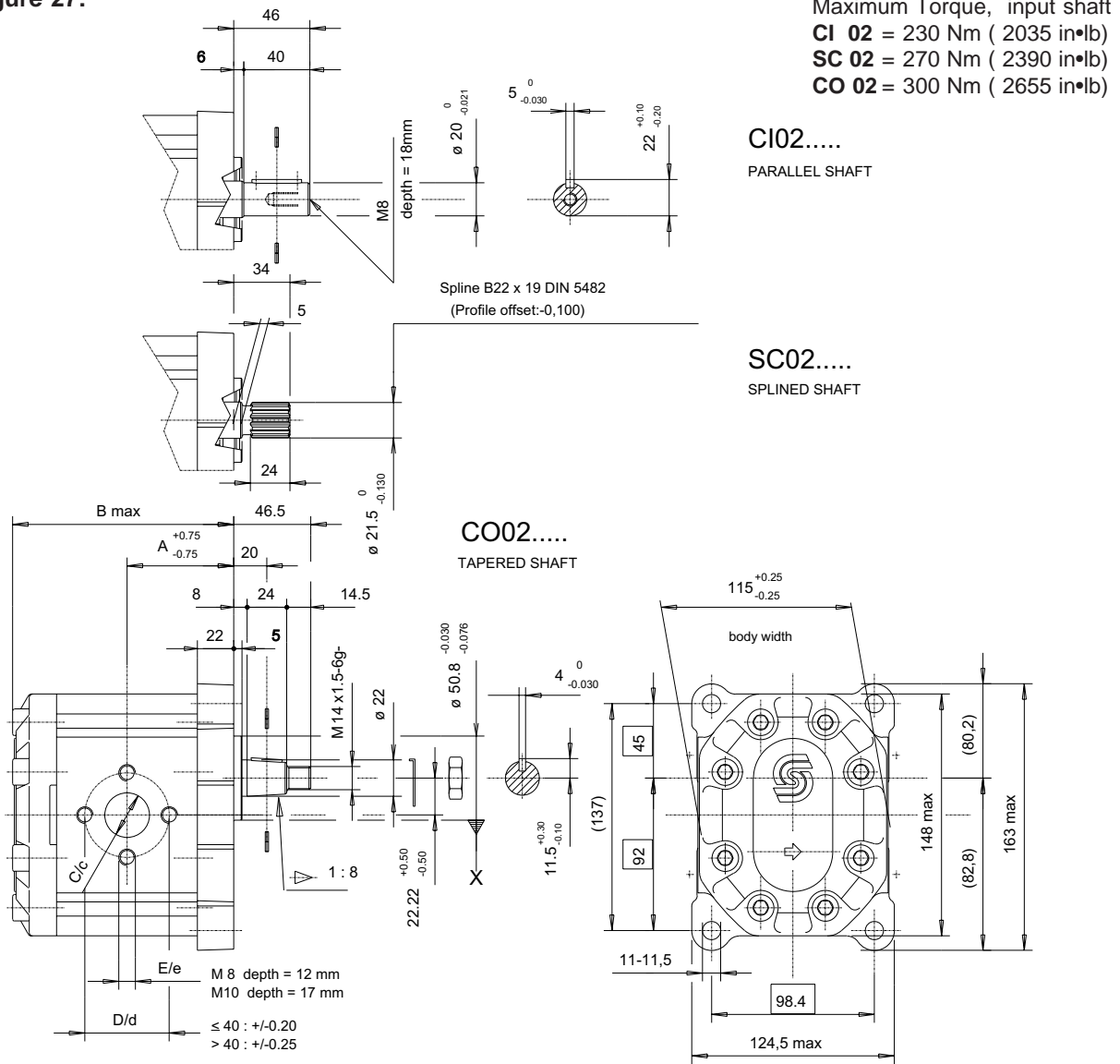

Table 3: Dimensions

SNP 3 Frame Size		44	48	55	63	75	90	
Dimensions	A	mm	71.00	72.50	75.00	78.00	82.00	87.00
		in	2.80	2.85	2.95	3.07	3.23	3.43
	B	mm	148.50	151.50	156.50	162.50	170.50	180.50
		in	5.85	5.96	6.16	6.40	6.71	7.11
	European Inlet Port	C	27 mm (1.06 in)			36 mm (1.42 in)		
		D	51 mm (2.01 in)			62 mm (2.44 in)		
		E	M10			M10		
	European Outlet Port	c	27 mm (1.06 in)					
		d	51 mm (2.01 in)					
		e	M10					

Dimensions for SNP3 Configurations CI 03 • CO 03 • SC 03

Figure 28:

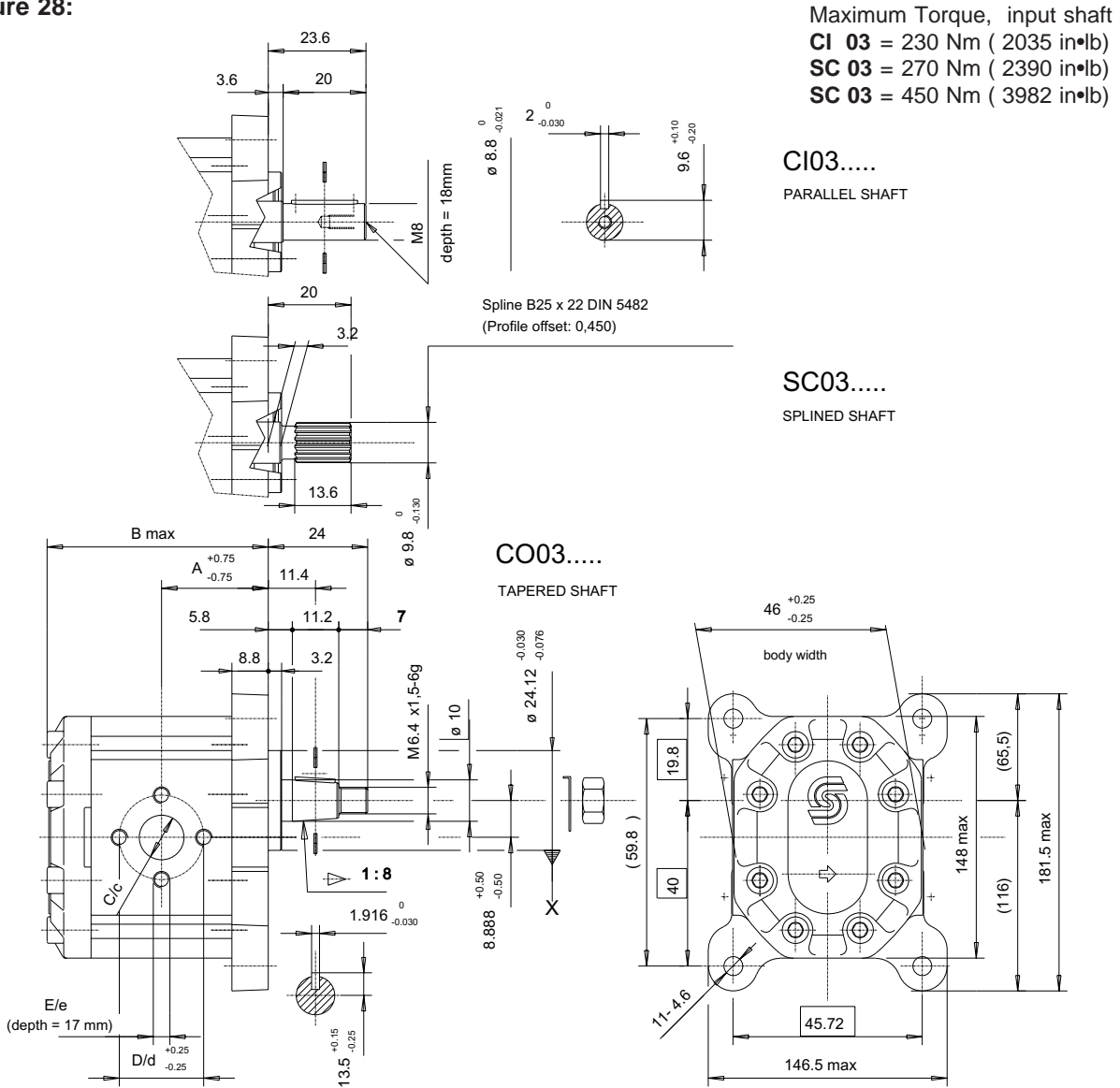

Table 4: Dimensions

SNP 3 Frame Size		44	48	55	63	75	90	
Dimensions	A	mm	71	72.5	75	78	82	87
		in	2.8	2.85	2.95	3.07	3.23	3.43
	B	mm	148.5	151.5	156.5	162.5	170.5	180.5
		in	5.85	5.96	6.16	6.4	6.71	7.11
	European Inlet Port	C	27 mm (1.06 in)			36 mm (1.42 in)		
		D	51 mm (2.01 in)			62 mm (2.44 in)		
		E	M10			M10		
	European Outlet Port	c	27 mm (1.06 in)					
		d	51 mm (2.01 in)					
		e	M10					

Dimensions for SNP3 Configurations CI 06 • CO 06 • SC 06.

Figure 29:

Maximum Torque, input shaft
CI 06 = 230 Nm (2035 in•lb)
SC 06 = 270 Nm (2390 in•lb)
SC 06 = 380 Nm (3363 in•lb)

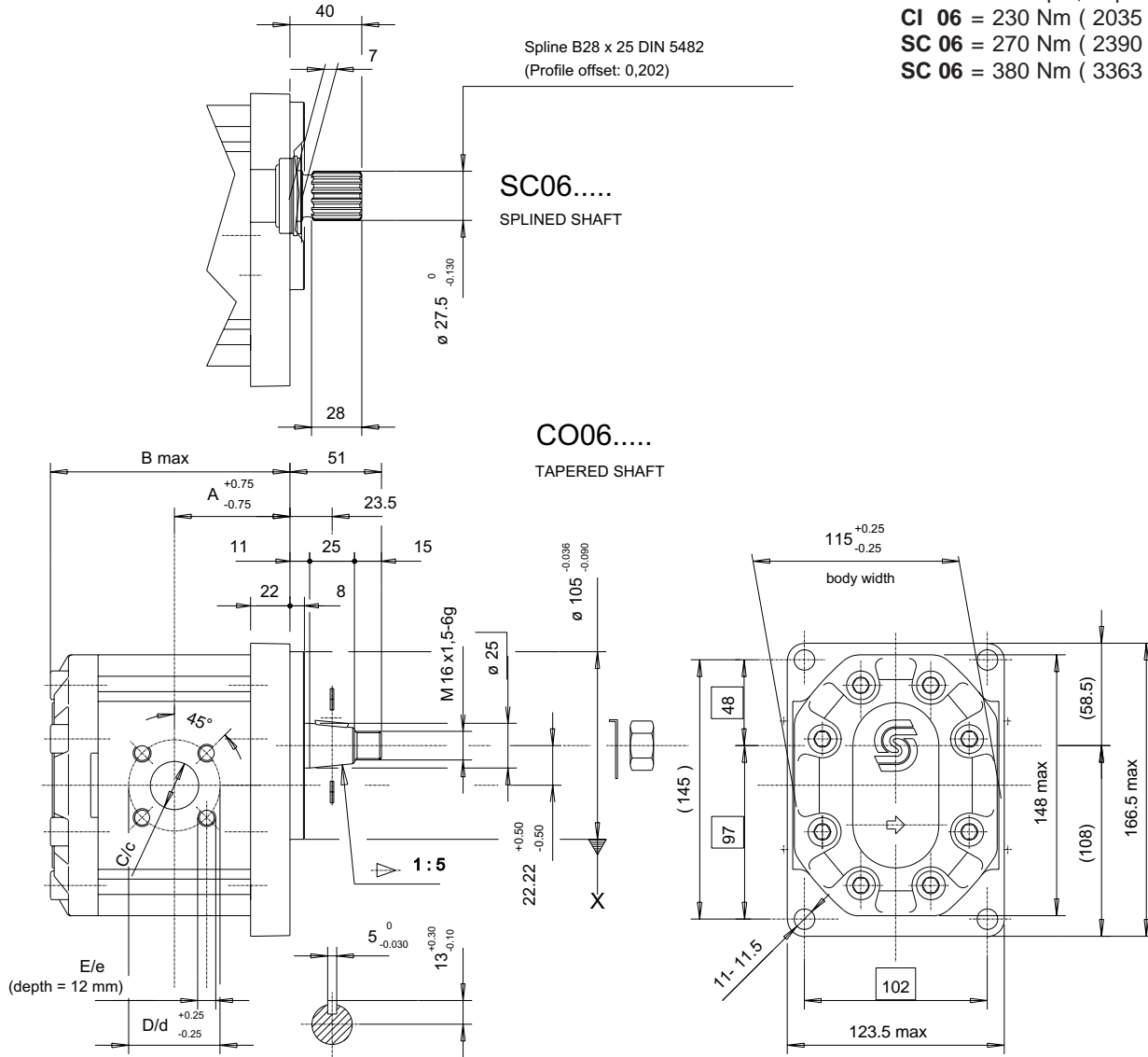
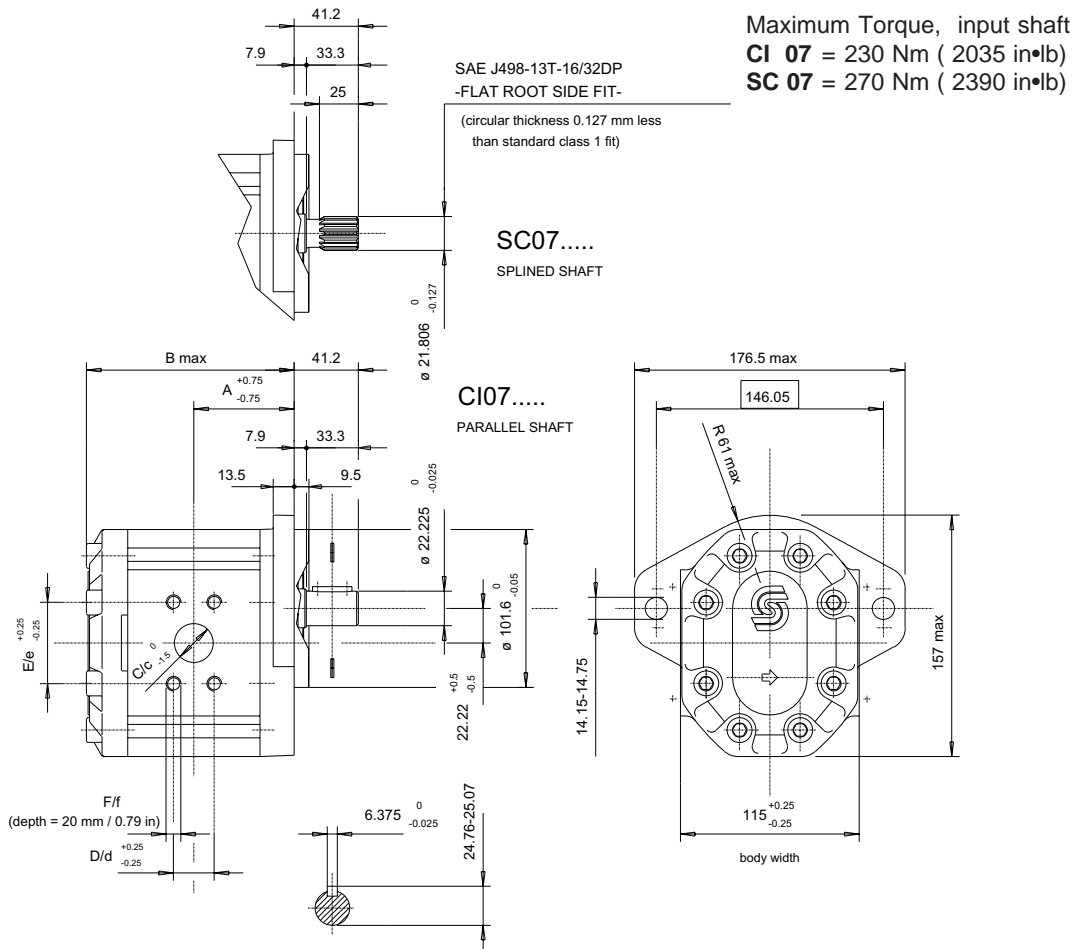

Table 5: Dimensions

SNP 3 Frame Size		22	26	33	38	44	55	
Dimensions	A	mm	63.00	64.50	67.00	68.80	71.00	75.00
		in	2.48	2.54	2.64	2.71	2.80	2.95
	B	mm	132.50	135.50	140.50	144.00	148.50	156.50
		in	5.22	5.33	5.53	5.67	5.85	6.16
	Bosch Inlet Port	C	27 mm (1.06 in)					
		D	55 mm (2.17 in)					
		E	M8					
	Bosch Outlet Port	c	18 mm (0.71 in)					
		d	55 mm (2.17 in)					
		e	M10					

Dimensions for SNP3 Configurations CI 07 • SC 07 / ¹⁾CI 07E • ¹⁾SC 07E

Figure 30:



¹⁾ CI07E and SC07E models have SAE O-ring ports.

Table 6: Dimensions

SNP 3 Frame Size		22	26	33	38	44	48	55	63	75	90	
Dimensions	A	mm	63.00	64.50	67.00	68.80	71.00	72.50	75.00	78.00	82.00	87.00
		in	2.48	2.54	2.64	2.71	2.80	2.85	2.95	3.07	3.23	3.43
	B	mm	132.50	135.50	140.50	144.00	148.50	151.50	156.50	162.50	170.50	180.50
		in	5.22	5.33	5.53	5.67	5.85	5.96	6.16	6.40	6.71	7.11
	SAE Split Flange Inlet Port (standard)	C	25.40 mm (1.00 in)			31.80 mm (1.25 in)			38.10 mm (1.50 in)			
		D	26.19 mm (1.03 in)			30.18 mm (1.19 in)			35.71 mm (1.41 in)			
		E	52.37 mm (2.06 in)			58.72 mm (2.31 in)			69.85 mm (2.75 in)			
		F	3/8-16UNC			7/16-14UNC			1/2-13UNC			
	SAE Split Flange Outlet Port (standard)	c	19.10 mm (0.75 in)			25.40 mm (1.00 in)			31.80 mm (1.25 in)			
		d	22.23 mm (0.88 in)			26.19 mm (1.03 in)			30.18 mm (1.19 in)			
		e	47.63 mm (1.88 in)			52.37 mm (2.06 in)			58.72 mm (2.31 in)			
		f	3/8-16UNC			3/8-16UNC			7/16-14UNC			
Opt. O-ring Ports	Inlet	C	1-5/16-12 UN 2B			1-5/8-12 UN 2B			1-7/8-12 UN 2B			
	Outlet	c	1-1/16-12 UN 2B			1-5/16-12 UN 2B			1-5/8-12 UN 2B			

Type Designation and Order Code, SNP3

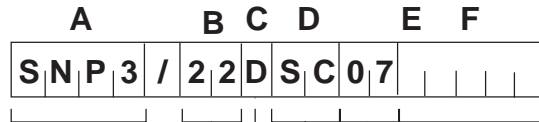

A: SERIES

SNP 3

B: DISPLACEMENT

- 22 = 22.1 cm³(1.35 in³)
- 26 = 26.2 cm³(1.60 in³)
- 33 = 33.1 cm³(2.02 in³)
- 38 = 37.9 cm³(2.32 in³)
- 44 = 2.69 cm³(2.69 in³)
- 48⁽¹⁾ = 48.3 cm³(2.93 in³)
- 55⁽¹⁾ = 55.1 cm³(3.36 in³)
- 63⁽¹⁾ = 63.4 cm³(3.87 in³)
- 75⁽¹⁾ = 74.4 cm³(4.54 in³)
- 90⁽¹⁾ = 88.2 cm³(5.38 in³)

Note: ⁽¹⁾only available in SNP3

E: Rotation

- D = Right (Clockwise)
- S = Left (Counterclockwise)

Order Example: SNP3 / 22 D SC 07E

Single gear pump SNP 3, displacement = 1.35 in³ (22.1 cm³) , clockwise rotation, splined shaft, SAE "B" 2 bolt mounting flange, SAE O-ring ports.

F: Special Options

- E = SAE O-Ring Boss (SNP3 only)
- F = BSP Threaded Ports, B.S.P.
- A = SAE code 61 ports on other than 07 code pumps (such as 11 code rear section for tandem)

E: Mounting Flange

- 01 } 4 bolt DIN mounting flange
- 02 }
- 03 }
- 06 }

- 07 = SAE "B" 2 bolt flange
- 11 = Flange code for Rear Section of Tandem

D: Drive Shaft

- CI = Straight Keyed Shaft With Key
- CO = Tapered shaft with key
- SC = Splined Shaft

NOTE: Refer to Configuration Dimensional detail on pages 17-21

SEP3 Technical Data

Table 7: SEP 3 (Design with One Piece Bearing & Pressure Plate, "01 & 07" Configuration Only)

SEP 3	Dimension	Frame Size								
		22	26	33	38	44				
Displacement	cm ³	22.1	26.2	33.1	37.9	44.1				
	in ³ /Rev	1.35	1.60	2.02	2.32	2.69				
Maximum Speed	rpm	3000	3000	3000	2800	2600				
	bar	180	180	180	180	160				
	psi	2610	2610	2610	2610	2320				
Maximum Pressure	bar	210	210	210	210	180				
	psi	3045	3045	3045	3045	2610				
	rpm	2500	2500	2500	2300	2300				
Maximum Peak Pressure	bar	230	230	230	230	200				
	psi	3335	3335	3335	3335	2910				
Minimum Speed at Maximum Pressure	rpm	1000	1000	1000	800	800				

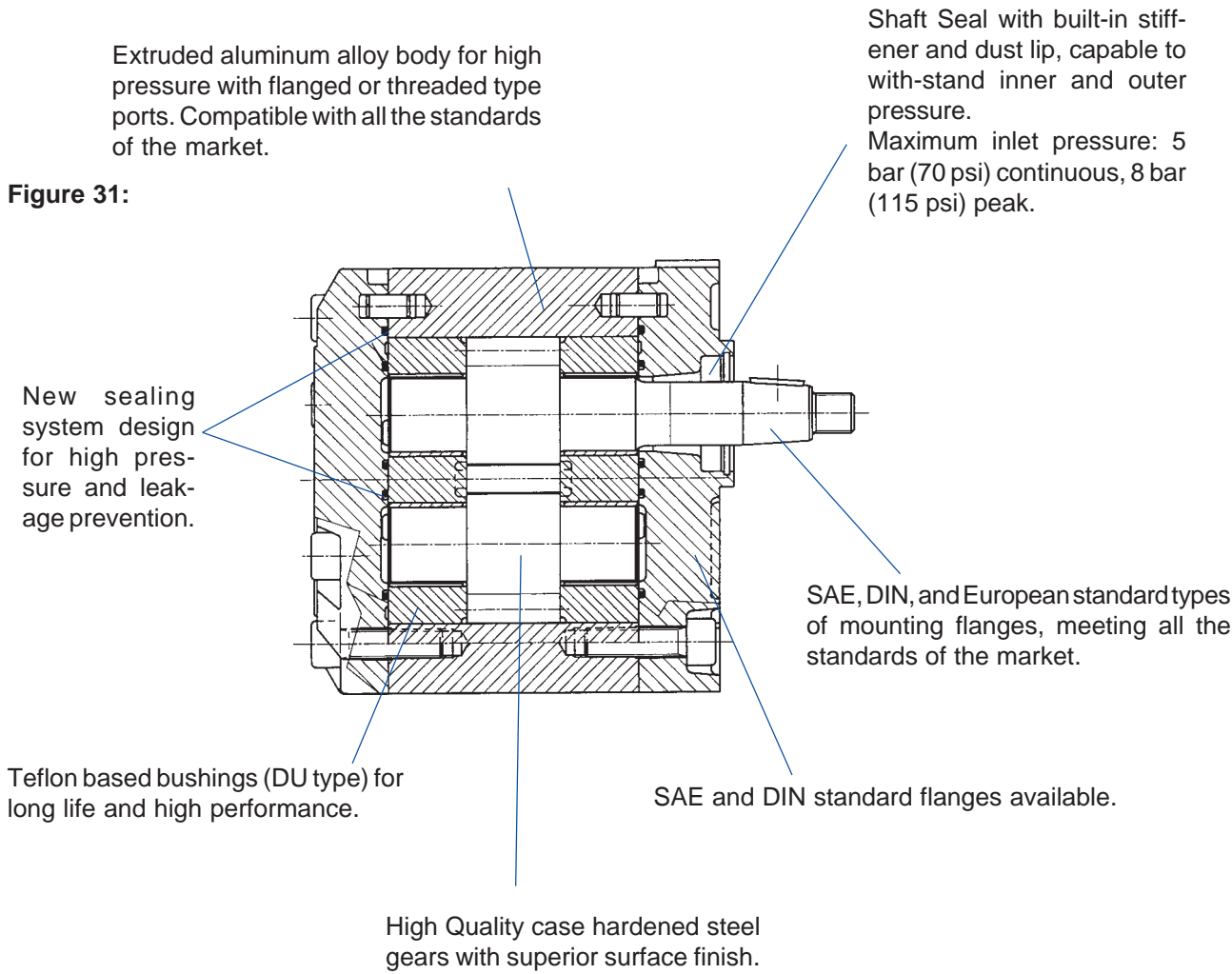

SEP3 Performance Curves

[$\nu = 25 \text{ mm}^2/\text{s}$ (120 SUS), $\vartheta = 50^\circ \text{ C}$ (122°F)]

Figure 32:

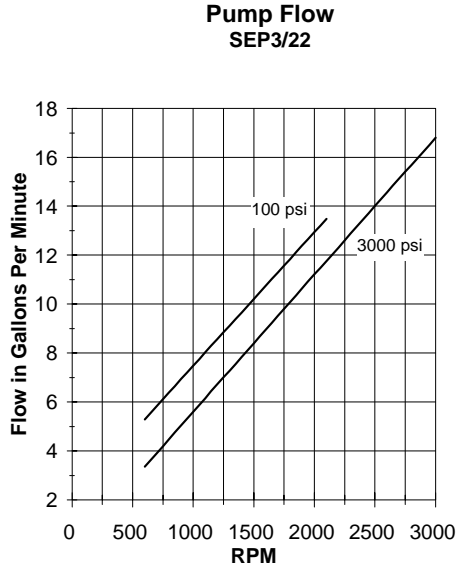

Figure 33:

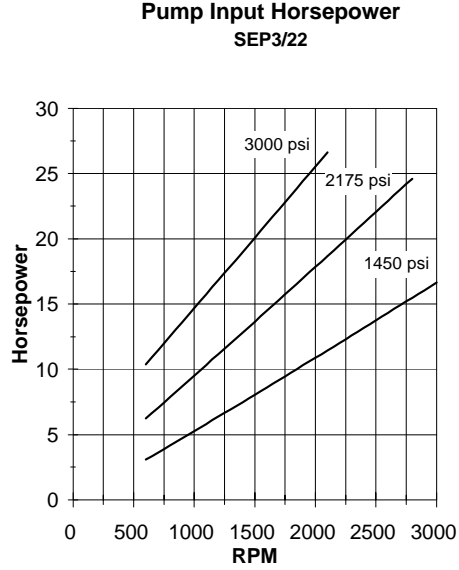

Figure 34:

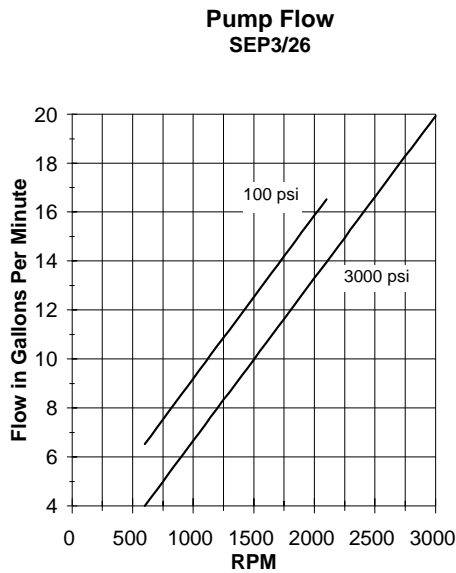
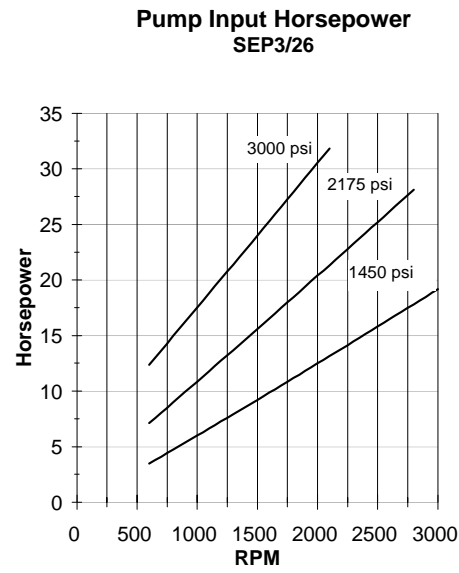

Figure 35:



SEP3 Performance Curves (Continued)

[$\nu = 25 \text{ mm}^2/\text{s}$ (120 SUS), $\vartheta = 50^\circ \text{ C}$ (122°F)]

Figure 36:

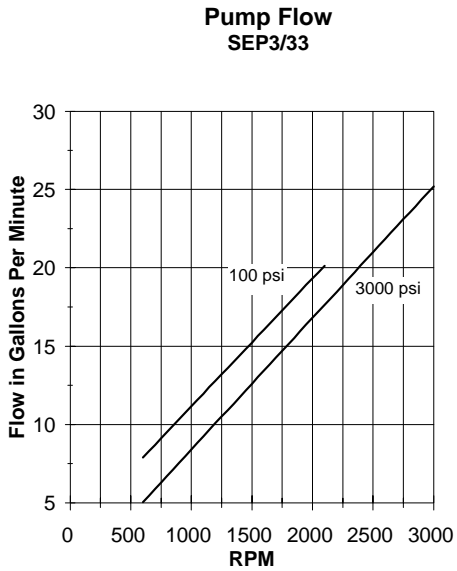

Figure 37:

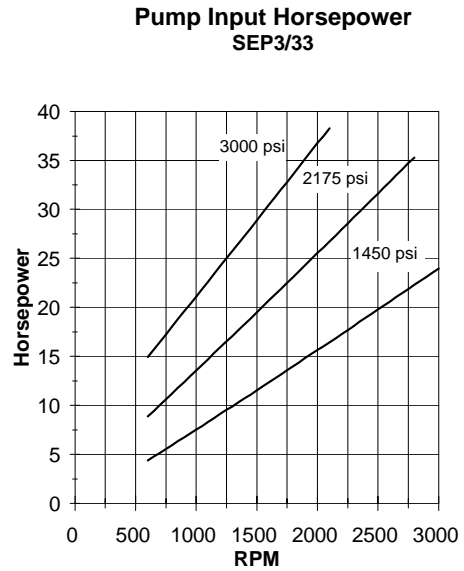

Figure 38:

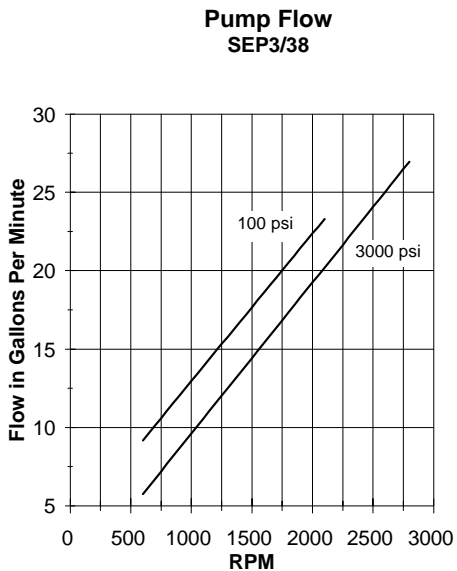
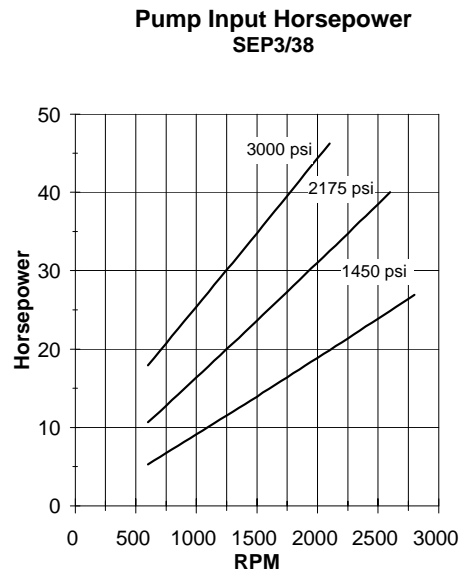

Figure 39:



SEP3 Performance Curves (Continued)

[$\nu = 25 \text{ mm}^2/\text{s}$ (120 SUS), $\vartheta = 50^\circ \text{ C}$ (122°F)]

Figure 40:

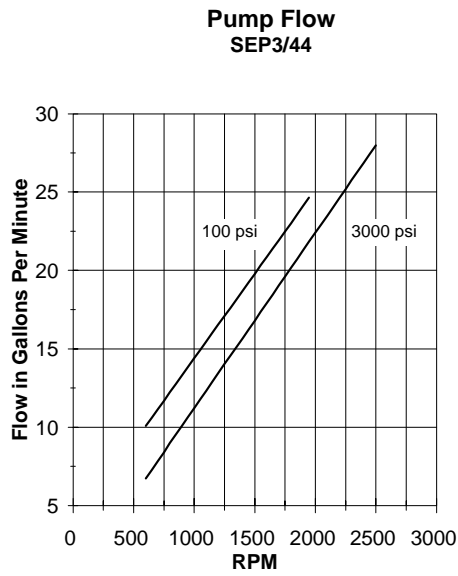
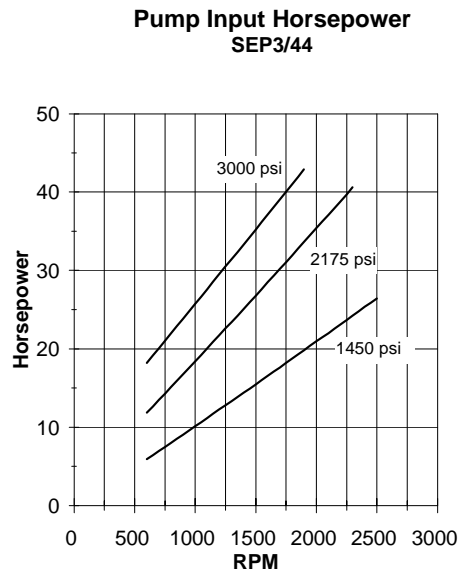

Figure 41:



Dimensions for SEP3 Configurations CI 01 • SC 01

Figure 42:

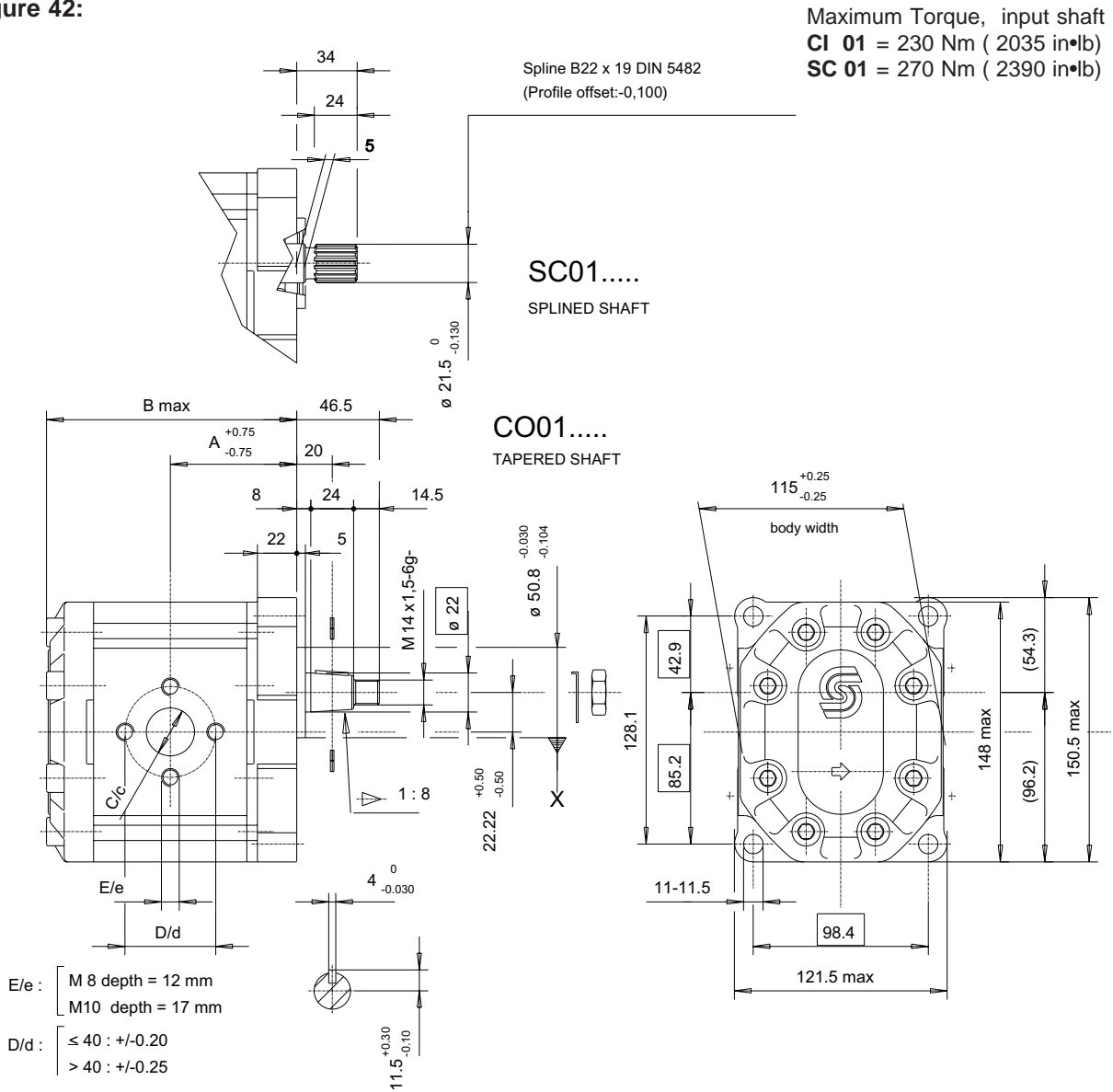
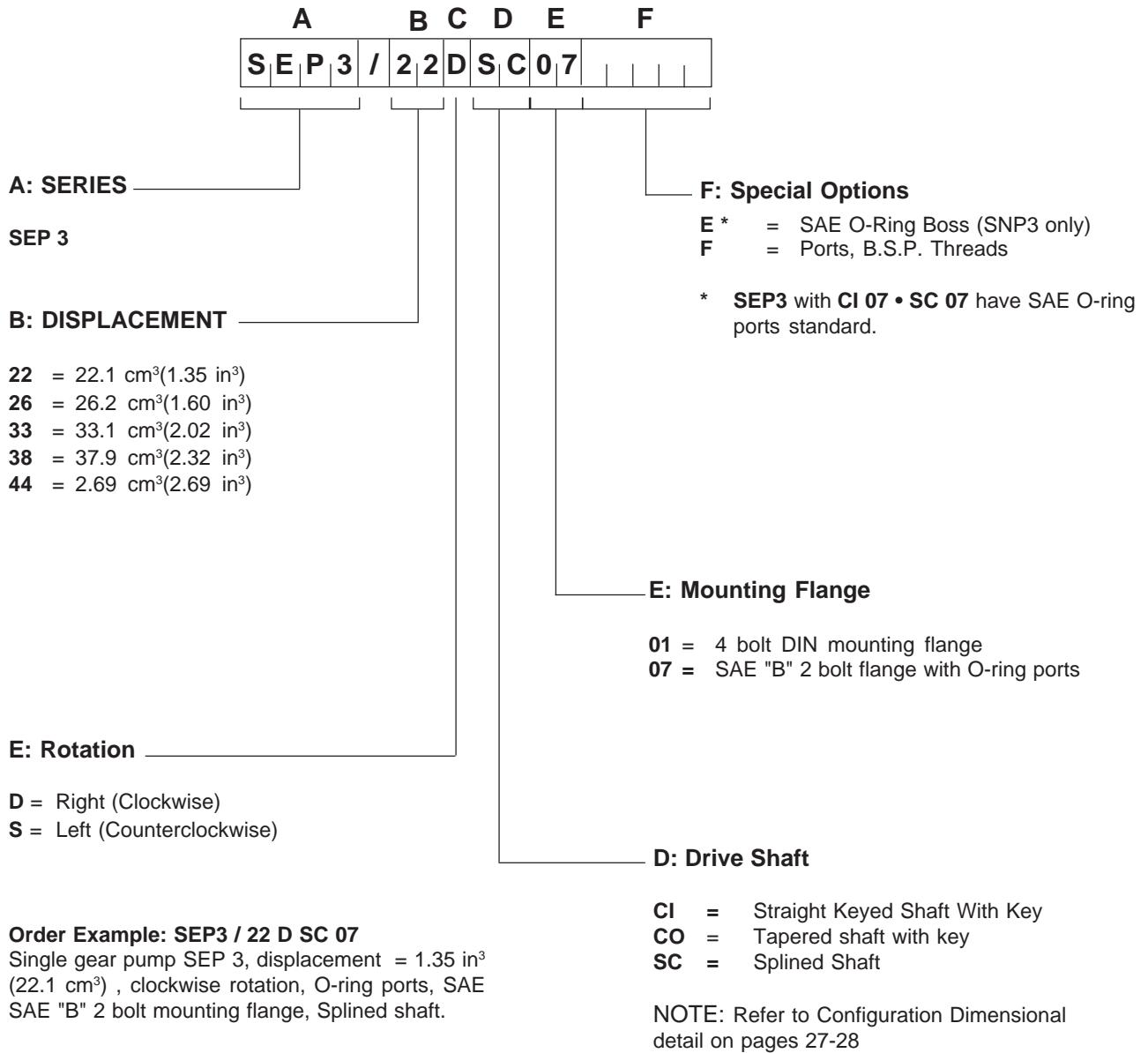

Table 8:

SEP 3 Frame Size		22	26	33	38	44	
Dimensions	A	63.00 mm (2.48 in)	64.50 mm (2.54 in)	67.00 mm (2.64 in)	68.80 mm (2.71 in)	71.00 mm (2.80 in)	
	B	132.50 mm (5.22 in)	135.50 mm (5.33 in)	140.50 mm (5.53 in)	144.00 mm (5.67 in)	148.50 mm (5.85 in)	
	European Inlet Port	C	20 mm (0.79 in)		27 mm (1.06 in)		
		D	40 mm (1.57 in)		51 mm (2.01 in)		
		E	M8		M10		
	European Outlet Port	c	20 mm (0.79 in)				27 mm (1.06 in)
d		40 mm (1.57 in)				51 mm (2.01 in)	
e		M8				M10	

Type Designation and Order Code, SEP3



SNP3 Tandems

Table 10:

Tandem Type	Tandem Coding	Second Section	Maximum Input Torque, *Front Section	Maximum Input Torque, **Second Section
SNP3 + SNP3 Group 3 + Group 3	PRR...CO41	SNP3 / ... 11	300 Nm / (2655 lb in)	*230 Nm / (2035 lb in)
	PRR...SC47	SNP3 / ... 11A	270 Nm / (2390 lb in)	*230 Nm / (2035 lb in)
	PRR...SC37...2	SNP3 / ... 07	270 Nm / (2390 lb in)	*230 Nm / (2035 lb in)
SNP3 + SNP2 Group 3 + Group 2	PRN...CO41	SNP2 / ... 01	300 Nm / (2655 lb in)	**90 Nm / (797 lb in)
	PRN...SC37	SNP2 / ... 01	270 Nm / (2390 lb in)	**90 Nm / (797 lb in)
	PRN...SC37...2	SNP2 / ... 06	270 Nm / (2390 lb in)	**90 Nm / (797 lb in)

* Torque limits must not exceed these levels, pressure and speed parameters listed on page 11 must not be exceeded regardless of input torque limits.

** Torque limits for SNP2 pumps must not exceed these levels when used as a second section of the tandem. Please refer to pressure and speed parameters listed in BLN-10071. Parameters such as pressure and speed listed in BLN-10071 must not be exceeded regardless of input torque limits.

Group 3 + Group 1 tandems (SNP3 + TFP100) are available. Please contact Sauer-Sundstrand for availability.

Dimensions for Tandem Gear Pump Configuration • PRR ... + CO 41 (SNP 3 + SNP 3)

Figure 44:

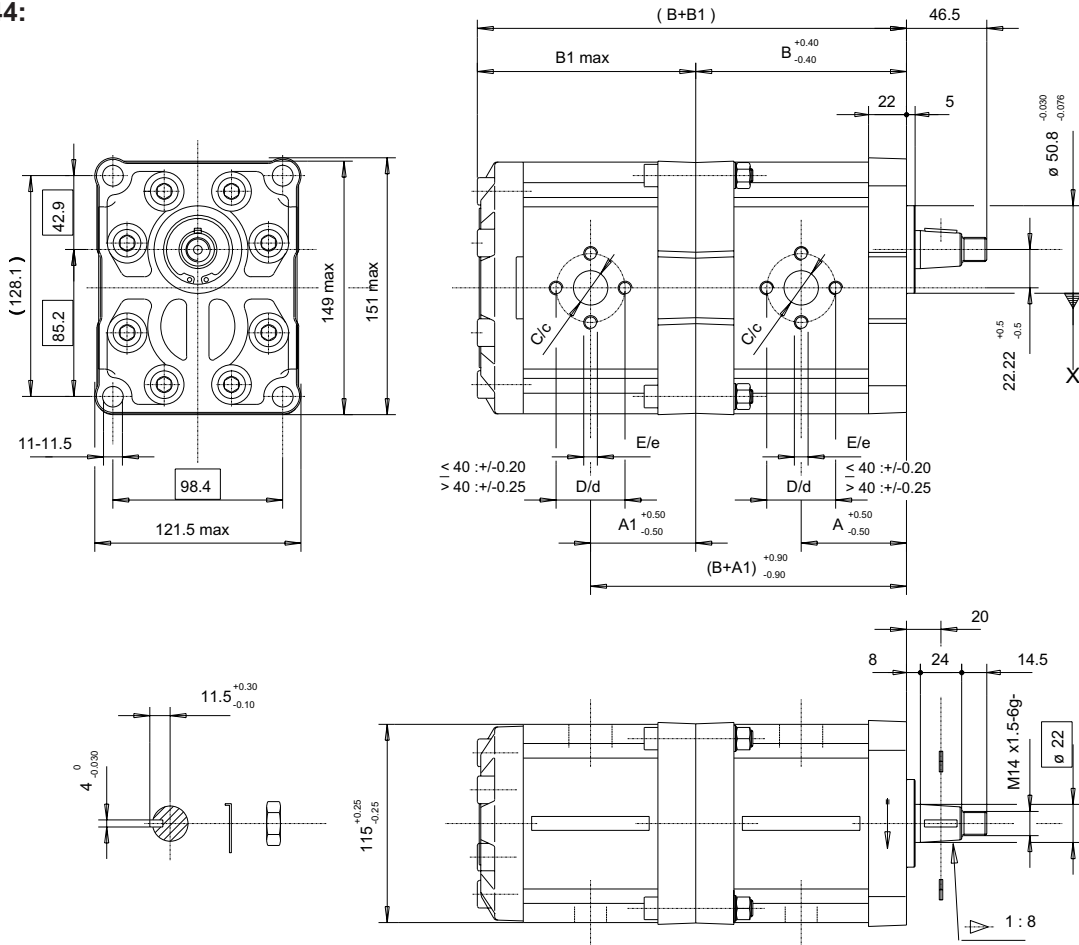

NOTE: This Tandem Requires Bolt Adapter Kit #B81922-1160K

Table 11: Dimensions

SNP 3 Frame Size		22	26	33	38	44	48	55		
Dimensions	A	mm	63.00	64.50	67.00	68.80	71.00	72.50	75.00	
		in	2.48	2.54	2.64	2.71	2.80	2.85	2.95	
	A1	mm	63.00	64.50	67.00	68.80	71.00	72.50	75.00	
		in	2.48	2.54	2.64	2.71	2.80	2.85	2.95	
	B	mm	126.10	129.10	134.10	137.60	142.10	145.10	150.10	
		in	4.96	5.08	5.28	5.42	5.59	5.71	5.91	
	B1	mm	132.50	135.50	140.50	144.00	148.50	151.50	156.50	
		in	5.22	5.33	5.53	5.67	5.85	5.96	6.16	
	European Inlet Port	C	20 mm (0.78 in)			27 mm (1.06 in)				
		D	40 mm (1.57 in)			51 mm (2.01 in)				
		E	M8			M10				
	European Outlet Port	c	20 mm (0.78 in)				27 mm (1.06 in)			
d		40 mm (1.57 in)				51 mm (2.01 in)				
e		M8				M10				

Dimensions for Tandem Gear Pump Configuration • PRR ... + SC 47 (SNP 3 + SNP 3)

Figure 45:

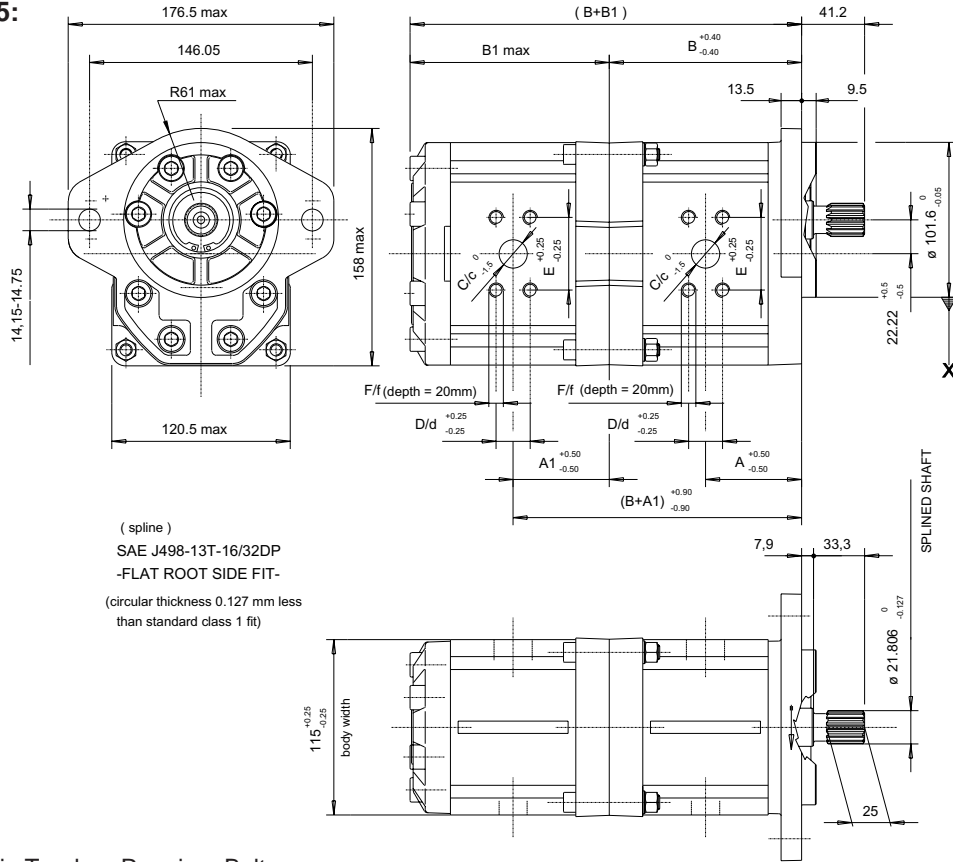

NOTE: This Tandem Requires Bolt Adapter Kit #B81922-1160K

Table 12: Dimensions

SNP 3 Frame Size		22	26	33	38	44	48	55	
Dimensions	A	mm	63.00	64.50	67.00	68.80	71.00	72.50	75.00
		in	2.48	2.54	2.64	2.71	2.80	2.85	2.95
	A1	mm	63.00	64.50	67.00	68.80	71.00	72.50	75.00
		in	2.48	2.54	2.64	2.71	2.80	2.85	2.95
	B	mm	126.10	129.10	134.10	137.60	142.10	145.10	150.10
		in	4.96	5.08	5.28	5.42	5.59	5.71	5.91
	B1	mm	132.50	135.50	140.50	144.00	148.50	151.50	156.50
		in	5.22	5.33	5.53	5.67	5.85	5.96	6.16
	SAE Code 61 Flange Inlet Port	C	25.40 mm (1.00 in)		31.80 mm (1.25 in)			38.10 mm (1.50 in)	
		D	26.19 mm (1.03 in)		30.18 mm (1.19 in)			35.71 mm (1.41 in)	
		E	52.37 mm (2.06 in)		58.72 mm (2.31 in)			69.85 mm (2.75 in)	
		F	3/8-16 UNC		7/16-14 UNC			1/2-13 UNC	
SAE Code 61 Flange Outlet Port	c	19.10 mm (0.75 in)		25.40 mm (1.00 in)			31.80 mm (1.25 in)		
	d	22.23 mm (0.88 in)		26.19 mm (1.03 in)			30.18 mm (1.19 in)		
	e	47.63 mm (1.88 in)		52.37 mm (2.06 in)			58.72 mm (2.31 in)		
	f	3/8-16 UNC		3/8-16 UNC			7/16-14 UNC		

Dimensions for Tandem Gear Pump Configuration • PRN ... + CO 31 (SNP 3 + SNP 3)

Figure 47:

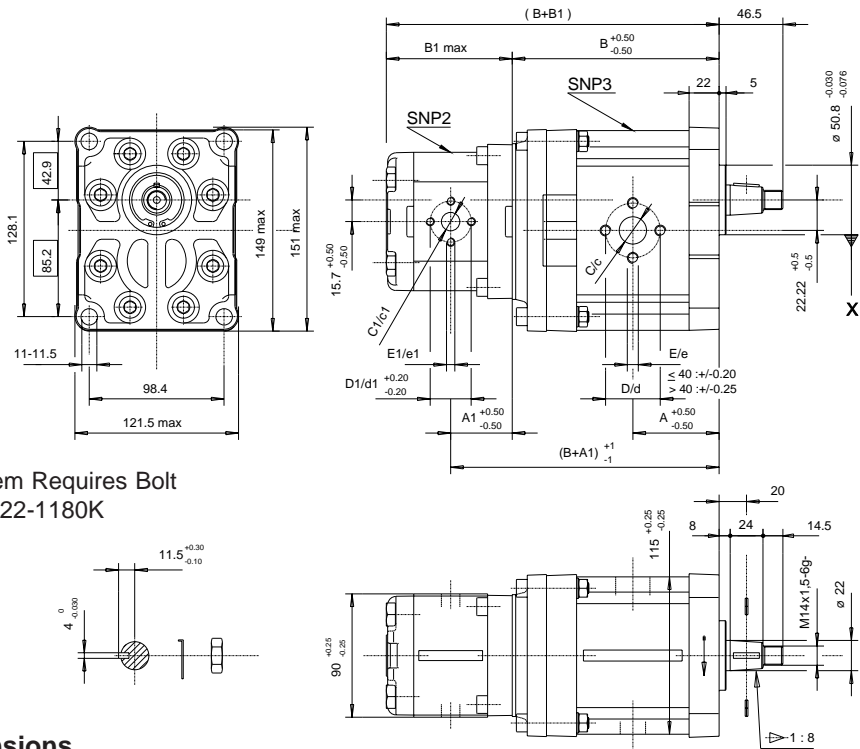

NOTE: This Tandem Requires Bolt Adapter Kit #B81922-1180K

Table 14: Dimensions

SNP 3 Frame Size		22	26	33	38	44	48	55			
Dimensions	A	mm	63.00	64.50	67.00	68.80	71.00	72.50	75.00		
		in	2.48	2.54	2.64	2.71	2.80	2.85	2.95		
	B	mm	151.10	154.10	159.10	162.60	167.10	170.10	175.10		
		in	5.95	6.07	6.26	6.40	6.58	6.70	6.89		
	European Inlet Port	C	20 mm (0.78 in)			27 mm (1.06 in)					
		D	40 mm (1.57 in)			51 mm (2.01 in)					
		E	M8			M10					
	European Outlet Port	c	20 mm (0.78 in)				27 mm (1.06 in)				
		d	40 mm (1.57 in)				51 mm (2.01 in)				
		e	M8				M10				
SNP 2 Frame Size		4	6	8	11	14	17	19	22	25	
Dimensions	A1	mm	43.25	45.00	49.00	52.00	56.00	59.00			
		in	1.70	1.77	1.93	2.05	2.20	2.32			
	B1	mm	90.00	93.50	97.50	101.50	107.50	111.50	115.50	121.50	125.50
		in	3.54	3.68	3.84	4.00	4.23	4.39	4.55	4.78	4.94
	European Inlet Port	C1	13.5 mm (0.53 in)			20 mm (0.79 in)			23.5 mm (0.93 in)		
		D1	30 mm (1.18 in)			40 mm (1.57 in)			40 mm (1.57 in)		
		E1	M6			M8					
	European Outlet Port	c1	13.5 mm (0.53 in)						20 mm (0.79 in)		
		d1	30 mm (1.18 in)						40 mm (1.57 in)		
		e1	M6						M8		

Dimensions for Tandem Gear Pump Configuration • PRN ... + SC 37 (SNP 3 + SNP 2)

Figure 48:

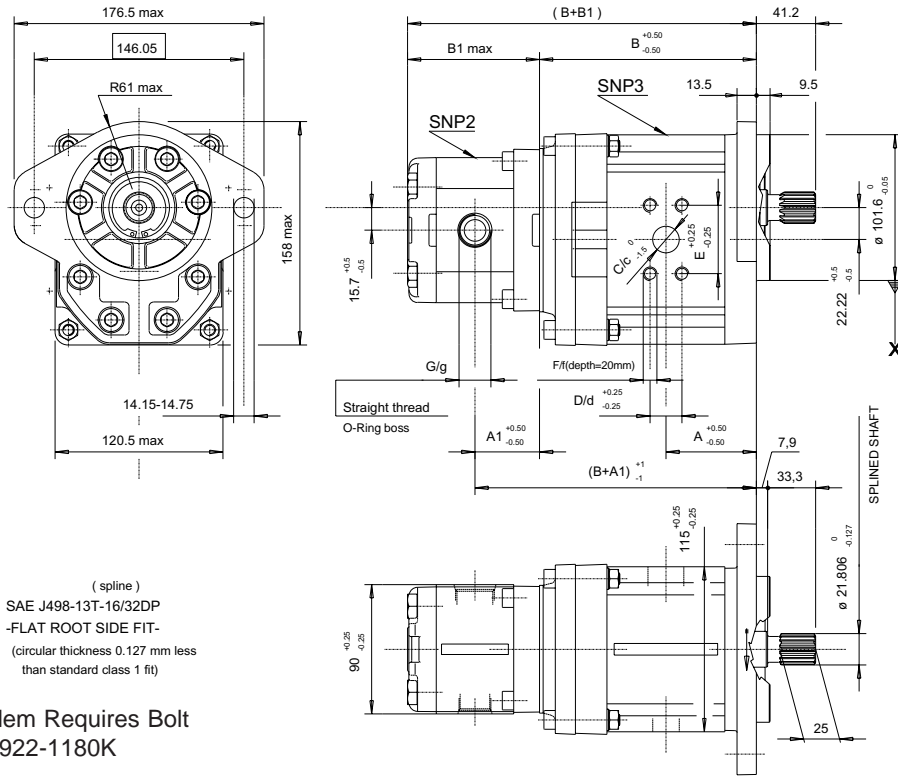

NOTE: This Tandem Requires Bolt Adapter Kit #B81922-1180K

Table 15: Dimensions

SNP 3 Frame Size			22	26	33	38	44	48	55			
Dimensions	A	mm	63.00	64.50	67.00	68.80	71.00	72.50	75.00			
		in	2.48	2.54	2.64	2.71	2.80	2.85	2.95			
	B	mm	151.10	154.10	159.10	162.60	167.10	170.10	175.10			
		in	5.95	6.07	6.26	6.40	6.58	6.70	6.89			
	SAE Code 61 Flange Inlet Port	C	25.40 mm (1.00 in)			31.80 mm (1.25 in)			38.10 mm (1.50 in)			
		D	26.19 mm (1.03 in)			30.18 mm (1.19 in)			35.71 mm (1.41 in)			
		E	52.37 mm (2.06 in)			58.72 mm (2.31 in)			69.85 mm (2.75 in)			
		F	3/8-16 UNC			7/16-14 UNC			1/2-13 UNC			
	SAE Code 61 Flange Outlet Port	c	19.10 mm (0.75 in)			25.40 mm (1.00 in)			31.80 mm (1.25 in)			
		d	22.23 mm (0.88 in)			26.19 mm (1.03 in)			30.18 mm (1.19 in)			
		e	47.63 mm (1.88 in)			52.37 mm (2.06 in)			58.72 mm (2.31 in)			
		f	3/8-16 UNC			3/8-16 UNC			7/16-14 UNC			
SNP 2 Frame Size			4	6	8	11	14	17	19	22	25	
Dimensions	A1	mm	43.25	45.00	47.00	49.00	52.00	54.00	56.00	59.00	61.00	
		in	1.70	1.77	1.85	1.93	2.05	2.13	2.20	2.32	2.40	
	B1	mm	90.00	93.50	97.50	101.5-0	107.5-0	111.5-0	115.-50	121.50	125.50	
		in	3.54	3.68	3.84	4.00	4.23	4.39	4.55	4.78	4.94	
	O-ring Inlet	G	SAE 1-1/16"-12 UN									
	O-ring Outlet	g	SAE 7/8"- 14 UN									

Dimensions for Tandem Gear Pump Configuration • PRN ... + SC 37...2 (SNP 3 + SNP 2)

Figure 49:

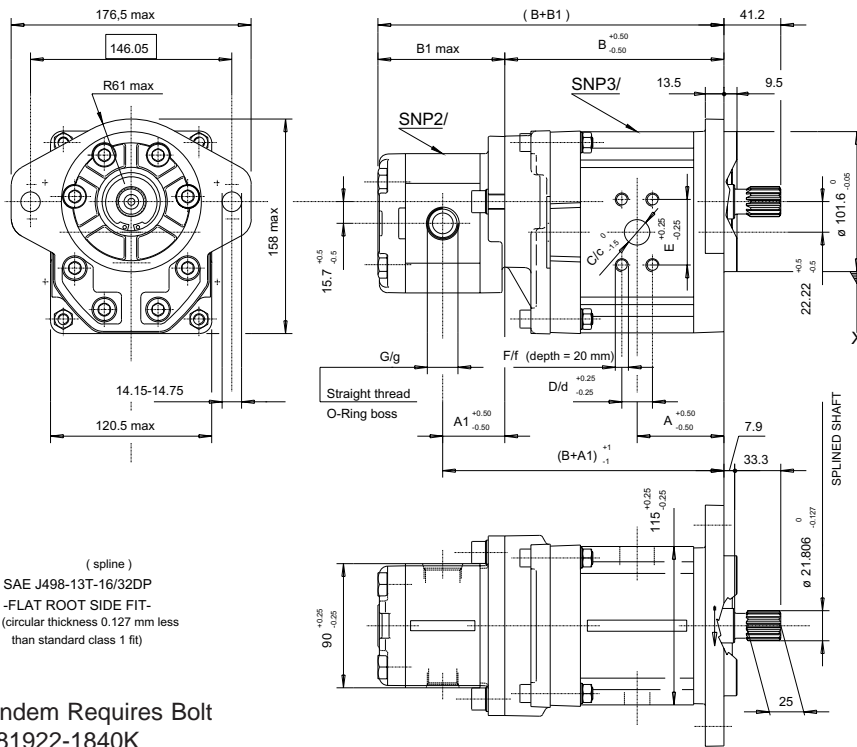

NOTE: This Tandem Requires Bolt Adapter Kit #B81922-1840K

Table 16: Dimensions

SNP 3 Frame Size		22	26	33	38	44	48	55			
Dimensions	A	mm	63.00	64.50	67.00	68.80	71.00	72.50	75.00		
		in	2.48	2.54	2.64	2.71	2.80	2.85	2.95		
	B	mm	159.10	162.10	167.10	170.60	175.10	178.10	183.10		
		in	6.26	6.38	6.58	6.72	6.89	7.01	7.21		
	SAE Code 61 Flange Inlet Port	C	25.40 mm (1.00 in)			31.80 mm (1.25 in)			38.10 mm (1.50 in)		
		D	26.19 mm (1.03 in)			30.18 mm (1.19 in)			35.71 mm (1.41 in)		
		E	52.37 mm (2.06 in)			58.72 mm (2.31 in)			69.85 mm (2.75 in)		
		F	3/8-16 UNC			7/16-14 UNC			1/2-13 UNC		
	SAE Code 61 Flange Outlet Port	c	19.10 mm (0.75 in)			25.40 mm (1.00 in)			31.80 mm (1.25 in)		
		d	22.23 mm (0.88 in)			26.19 mm (1.03 in)			30.18 mm (1.19 in)		
e		47.63 mm (1.88 in)			52.37 mm (2.06 in)			58.72 mm (2.31 in)			
f		3/8-16 UNC			3/8-16 UNC			7/16-14 UNC			
SNP 2 Frame Size		4	6	8	11	14	17	19	22	25	
Dimensions	A1	mm	43.25	45.00	47	49.00	52.00	54	56.00	59.00	61
		in	1.70	1.77	1.85	1.93	2.05	2.13	2.20	2.32	2.40
	B1	mm	90.00	93.50	97.50	101.5-0	107.5-0	111.5-0	115.-50	121.50	125.50
		in	3.54	3.68	3.84	4.00	4.23	4.39	4.55	4.78	4.94
	O-ring Inlet	G	SAE 1-1/16"-12 UN								
	O-ring Outlet	g	SAE 7/8"- 14 UN								

Type Designation and Order Code, SNP3 Tandems

PRR (SNP3 + SNP3) or PRN (SNP3 + SNP2)

A	B	C	D	E	F	G	H
P	R N	2 5	+	2 5	S S S	3 7	

A: Tandem Pump Designation

B: Front/Rear Section Series Code
 RN=SNP3/47 Front + SNP2/SC 06 Rear
 RR=SNP3/47 Front + SNP3/SC 07 Rear
 or
 SNP3/47 Front + SNP3/SC 11A Rear

C: Front Section (SNP3)	D: Rear Section (SNP2)
22 = 22.1 cm ³ (1.35 in ³)	4 = 3.9 cm ³ (0.24in ³)
26 = 26.2 cm ³ (1.60 in ³)	5 ²⁾ = 5.0 cm ³ (0.31in ³)
33 = 33.1 cm ³ (2.02 in ³)	6 = 6.0 cm ³ (0.37in ³)
38 = 37.9 cm ³ (2.32 in ³)	8 = 8.4 cm ³ (0.51in ³)
44 = 2.69 cm ³ (2.69 in ³)	11 = 10.8 cm ³ (0.66in ³)
48 ¹⁾ = 48.3 cm ³ (2.93 in ³)	12 ²⁾ = 12.3 cm ³ (0.75in ³)
55 ¹⁾ = 55.1 cm ³ (3.36 in ³)	14 = 14.4 cm ³ (0.88in ³)
63 ¹⁾ = 63.4 cm ³ (3.87 in ³)	17 = 16.8 cm ³ (1.03in ³)
75 ¹⁾ = 74.4 cm ³ (4.54 in ³)	19 = 19.2 cm ³ (1.17in ³)
90 ¹⁾ = 88.2 cm ³ (5.38 in ³)	22 = 22.8 cm ³ (1.39in ³)
	25 = 25.2 cm ³ (1.54in ³)

¹⁾ Not available with SEP3 (SNP3 only for front section)
²⁾ Contact Sauer-Sundstrand for availability

E: Rotation
 D = Right (Clockwise)
 S = Left (Counterclockwise)

H: Special Options
 E* = SAE O-Ring Boss (SNP3 only)
 A = SAE code 61 ports on other than 07 code pumps (such as 11 code rear section).
 * SEP3 07 configurations have SAE O-ring ports standard.

G: Mounting Flange

41 }
 42 } 4 bolt DIN mounting flange
 43 }
 46 }

37...2 = SAE "B" 2 bolt front flange(uses SAE Rear Section SNP2)

47 = SAE "B" 2 bolt front flange,uses DIN Rear Section SNP2 (not North American Standard).

11 = Flange code for Rear Section of Tandem

F: Drive Shaft

CI = Straight Keyed Shaft With Key
 CO = Tapered shaft with key
 SC = Splined Shaft

Order Example: PRRN 22 + 8 S SC 37...2

Tandem gear pump PRRN, Front section displacement = : 22.1 cm³ (1.54 in³), rear section displacement = : 8.4 cm³ (0.51in³), counterclockwise rotation, splined shaft, SAE "B" 2 bolt mounting flange.

NOTE: Refer to Configuration Dimensional detail on pages 31-36

Flow vs Speed

Table 17:

Theoretical Flow vs Speed, for Reference Only											
Frame Size	Speed	1200 RPM		1500 RPM		2000 RPM		2500 RPM		3000 RPM	
	Units	l/min	GPM	l/min	GPM	l/min	GPM	l/min	GPM	l/min	GPM
22	Flow	26.52	7.01	33.15	8.76	44.20	11.68	55.25	14.60	110.50	29.19
26		31.44	8.31	39.30	10.38	52.40	13.84	65.50	17.30	131.00	34.61
33		39.72	10.49	49.65	13.12	66.20	17.49	82.75	21.86	165.50	43.72
38		45.48	12.01	56.85	15.02	75.80	20.02	94.75	25.03	189.50	50.06
44		52.92	13.98	66.15	17.47	88.20	23.30	110.25	29.12	220.50	58.25
*48		57.96	15.31	72.45	19.14	96.60	25.52	120.75	31.90	241.50	63.80
*55		66.12	17.47	82.65	21.83	110.20	29.11	137.75	36.39	275.50	72.78
*63		76.08	20.10	95.10	25.12	126.80	33.50	158.50	41.87	317.00	83.74
*75		89.28	23.59	111.60	29.48	148.80	39.31	186.00	49.14	372.00	98.27
*90		105.84	27.96	132.30	34.95	176.40	46.60	220.50	58.25	441.00	116.50

* = Available only for SNP3







Hydraulic Power Systems

SAUER-SUNDSTRAND Hydraulic Power Systems - Market Leaders Worldwide

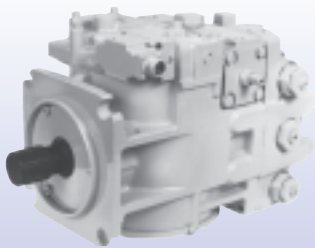
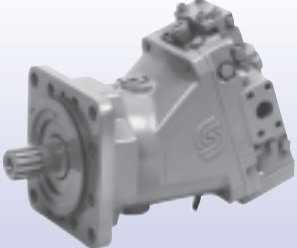
SAUER-SUNDSTRAND is a world leader in the design and manufacture of Hydraulic Power Systems. Research and development resources in both North America and Europe enable SAUER-SUNDSTRAND to offer a wide range of design solutions utilizing hydraulic power system technology.

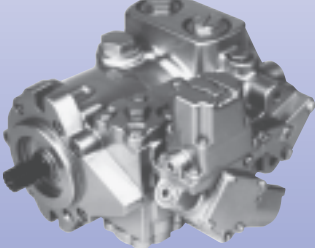
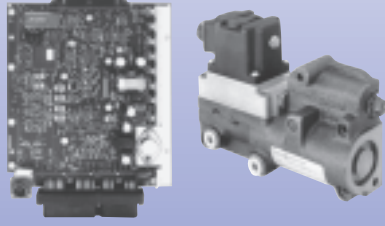
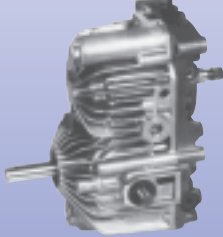
SAUER-SUNDSTRAND specializes in integrating a full range of system components to provide vehicle designers with the most advanced total-design system.

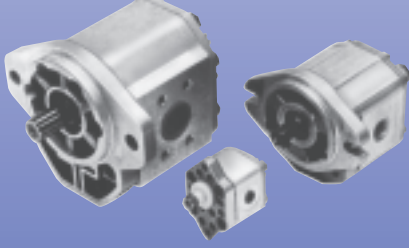
SAUER-SUNDSTRAND is Your World Source for Controlled Hydraulic Power Systems.

 <p>Heavy Duty Axial Piston Pumps and Motors</p>	 <p>Heavy Duty Bent Axis Variable Motors</p>	 <p>Cartridge Motors/ Compact Wheel Drives</p>
 <p>Medium Duty Axial Piston Pumps and Motors</p>	 <p>Mikrocontrollers and Electrohydraulic Controls</p>	 <p>Hydrostatic Transmissions Packages</p>
 <p>Open Circuit Axial Piston Pumps</p>	 <p>Gear Pumps and Motors</p>	 <p>Genuine Service Parts</p>

Worldwide Service Support

SAUER-SUNDSTRAND provides comprehensive worldwide service for its products through an extensive network of Authorized Service Centers strategically located in all parts of the world.

Look to SAUER-SUNDSTRAND for the best in WORLDWIDE SERVICE.

